

INSTALLATION AND MAINTENANCE INSTRUCTIONS

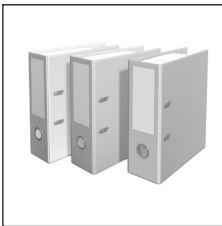

Technical data



Operating instructions



Electric diagrams

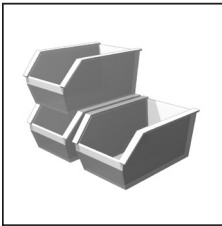

Spare parts list

420010904800

General Information

TABLE OF CONTENTS

1 GENERAL INFORMATION	3
1.1 Symbols used in the manual	3
1.2 Appropriate use of appliance	3
1.3 Water treatment	3
1.4 Information for user or system manager	3
1.5 Safety warnings	4
1.6 Technical data plate	5
1.7 General warnings	6
2 TECHNICAL FEATURES AND DIMENSIONS	7
2.1 Technical features	7
2.2 Main components	7
2.3 Smoke turbulators	8
2.4 Dimensions	9
2.5 Operating data according to UNI 10348	14
3 INSTALLATION INSTRUCTIONS	15
3.1 General warnings	15
3.2 Installation standards	16
3.3 Handling	17
3.4 Positioning in boiler room	17
3.5 Burner	17
3.5.1 - Choosing the burner	17
3.5.2 Installing the burner	18
3.6 Connecting flame sight glass to burner	18
3.7 Furnace door adjustment, opening and closing	19
3.7.1 65-N÷ 85-N boilers	19
3.7.2 110-N÷ 380-N boilers	19
3.7.3 500-N÷ 730-N boilers	20
3.7.4 840-N÷ 1900-N boilers	20
3.7.5 Important note	20
3.8 Connecting flue exhaust pipe	21
3.9 Condensation drainage	21
3.10 Connecting boiler to system	22
3.10.1 Recirculation pump	22
3.11 Filling the system	22
3.12 Connecting gas	23
3.13 Packaging	24
3.14 Assembling casing	25
3.15 Electrical connections	34
4 STANDARD PANEL BOARD	35
4.1 Panel board functions description	35
4.2 Electrical wiring diagram of a generic burner to the basic control panel	36
4.3 Electrical wiring diagram of an elco single phase burner to the basic control panel	37
4.4 Electrical wiring diagram of an elco three phase burner to the basic control panel	38
4.5 Electrical wiring diagram of an ecoflam single phase burner to the basic control panel	39
4.6 Electrical wiring diagram of an elco three phase burner to the basic control panel	40
4.9 Commissioning	41
4.10 Adjusting the burner	42
4.11 Removing flue gas turbulators	42
5 INSPECTIONS AND MAINTENANCE	43
Inspection and maintenance instructions	43
Boiler body maintenance	44
Maintenance of burner	44
Checking ignition electrode	44
Components to check during yearly inspection	44

Attention: this manual contains instructions for the exclusive use of the professionally qualified installer and/or maintenance technician in compliance with current legislation.

The user is NOT qualified to intervene on the boiler.

The manufacturer will not be held liable in case of damage to persons, animals or objects resulting from failure to comply with the instructions contained in the manuals supplied with the boiler.

1 GENERAL INFORMATION

1.1 - SYMBOLS USED IN THE MANUAL

Pay special attention when reading this manual to the parts marked by the symbols:



DANGER!
Serious danger for personal safety and life



ATTENTION!
Possible hazardous situation for the product and the environment



NOTE!
Suggestions for the user

1.2 - APPROPRIATE USE OF APPLIANCE



The TRIMAX 3SC appliance has been built according to the current level of engineering and acknowledged technical safety rules.

Nonetheless, if improperly used, dangers could arise for the safety and the very life of the user and other persons or damage to the equipment or other objects.

The appliance is intended to operate in hot air circulation heating systems.

Any other use must be considered improper.

Ecoflam shall not be held liable for any damage resulting from improper use; in this case the user is fully responsible for the risk.

Use according to the intended purposes also includes careful compliance with the instructions in this manual.

1.3 - WATER TREATMENT (see specific booklet)



- The hardness of the feed water conditions the frequency at which the domestic hot water exchanger must be cleaned.
- If the water has a hardness greater than 15°f, we recommend using water softeners, chosen according to the characteristics of the water.
- We recommend checking and cleaning the domestic hot water exchanger at the end of the first year of use and every two years thereafter; on this occasion, also check the state of wear of the anode.

1.4 - INFORMATION FOR SYSTEM MANAGER



- The user must be instructed concerning the use and operation of his heating system, in particular:
- Deliver these instructions to the user, as well as other documents concerning the appliance inserted in the envelope contained in the packaging. **The user must keep this documentation so that it is available for further consultation.**
- Inform the user about the importance of the air vents and the flue gas exhaust system, highlighting their essential features and the absolute prohibition of modifying them.
- Inform the user concerning controlling the system's water pressure as well as operations to restore it.
- Inform the user concerning correct temperature control, control units/thermostats and radiators for saving energy.
- Remember that the system must receive regular maintenance at least once a year and a combustion analysis must be performed in the timetable foreseen by standards in force.
- Should the appliance be sold or transferred to a new owner or if you move and leave the appliance, always make sure that the instruction booklet accompanies it in order to be consulted by the new owner and/or installer.

General Information

1.5 - SAFETY WARNINGS



ATTENTION!

The appliance must be installed, adjusted and maintained by professionally qualified personnel, in compliance with standards and provisions in force. Incorrect installation can cause damage to persons, animals and objects for which the manufacturer cannot be held responsible.



DANGER!

NEVER attempt performing maintenance or repairs on the boiler on your own initiative.

Any work must be done by professionally qualified personnel.

We recommend stipulating a maintenance contract.

Insufficient or irregular maintenance can jeopardise the operating safety of the appliance and cause damage to persons, animals and objects for which the manufacturer cannot be held responsible.



Modifying parts connected to appliance

Do not modify the following parts:

- the boiler
- the gas, air, water and electricity lines
- flue gas pipe, safety valves and heating water drain pipe
- construction parts which affect the operating safety of the appliance



Attention!

To tighten or loosen the screwed fittings, use only appropriate fixed spanners.

Incompliant use and/or inappropriate tools can cause damage (e.g. water or gas leakage).



ATTENTIO!

Indications for propane gas-fired appliances

Make sure that the gas tank has been deaerated before installing the appliance.

For state-of-the-art deaeration of the tank, contact the LPG supplier or a person qualified in compliance with law.

If the tank has not been professionally deaerated, ignition problems could arise.

In that case, contact the supplier of the LPG tank.



Smell of gas

Should a smell of gas be perceived, follow these safety guidelines:

- do not turn electric switches on or off
- do not smoke
- do not use the telephone
- close the gas shut-off valve
- air out the area where the gas leakage has occurred
- inform the gas supplier or a company specialised in installation and maintenance of heating systems.



Explosive and easily flammable substances

Do not use or store explosive or easily flammable materials (e.g. petrol, paints, paper) in the room where the appliance is installed.

1.6 - TECHNICAL DATA PLATE

The technical data plate is adhesive and is included in the document case; it must be applied by the installer on the outside of the casing.

The serial number of the boiler is on the riveted plaque on the front plate of the body (front right bottom side).

CE marking

The CE markings certifies that the boilers meet:

- The essential requirements of the gas appliance directive (90/396/EEC)
- The essential requirements of the electromagnetic compatibility directive (89/336/EEC)
- The essential requirements of the efficiency directive (92/42/EEC)

Model			
S.N°		Year	
	GAS	SOLID	
Fuel type:	<input type="checkbox"/> 1	<input type="checkbox"/> 2	<input type="checkbox"/> 3
Pn	kW	kW	kW
Pcond	kW	kW	kW
Qmax	kW	kW	kW
Adjusted Qn	kW	kW	kW
	kW	kW	kW
PIN	kW	kW	kW
	Stock <input style="width: 40px;" type="text"/> l	PMS <input style="width: 40px;" type="text"/> bar	T max <input style="width: 40px;" type="text"/> °C
	Stock <input style="width: 40px;" type="text"/> l	PMW <input style="width: 40px;" type="text"/> bar	T max <input style="width: 40px;" type="text"/> °C
	230 V - 50 Hz		
	See Burner - Vedi Bruciatore - Voir Bruleur		
Note:			

Symbol	EN	IT
Model	Boiler Model	Modello Caldaia
S.N° (*)	Serial Number: see on boiler body	Matricola: vedi il numero di fabbricazione sul corpo caldaia
Year	Year of manufacturing	Anno di costruzione
Fuel type:	Fuel 1 - Gas 2 - Oil 3 - Heavy Oil	Combustibile 1 - Gas 2 - Gasolio 3 - Nafta
Pn	Nominal OUTPUT	Potenza Utile nominale
Pcond	Condensing nom. output	Pot. Utile nom. in condensazione
Qn	Nominal heat INPUT	Portata Termica nominale
Adjusted Qn	Adj. for nom. heat input	Portata Termica Regolata a ...
CE	Surveillance notified body	Ente di sorveglianza CE
PIN	P.I.N. code	Numero Identificazione Prodotto
	BOILER heating circuit:	Circuito riscaldamento CALDAIA:
Stock	Water content	Contenuto acqua
PMS	Max. Working Pressure	Pressione Massima d'Esercizio
T.max	Max. Working Temperature	Temperatura Massima d'Esercizio
	D.H.W. TANK:	BOLLITORE A.C.S.
Stock	Water content	Contenuto acqua
PMW	Max. Working Pressure	Pressione Massima d'Esercizio
T.max	Max. Working Temperature	Temperatura Massima d'Esercizio
	Electrical power supply	Alimentazione Elettrica
	Destination Countries: (SEE BURNER)	Paesi di destinazione: (vedi bruciatore)
Note	(Condensing boiler)	(caldaia a condensazione)

General Information

1.7 - GENERAL WARNINGS

The instruction booklet is an integral and essential part of the product and must be kept by the user or system manager.

Read the warnings contained in this instruction booklet carefully as they provide important guidelines regarding installation, use and maintenance safety.

Keep the booklet with care for further consultation.

Installation and maintenance must be performed in compliance with standards in force according to the instructions of the manufacturer and by qualified and certified personnel in compliance with law.

By professionally qualified personnel we mean: personnel with specific technical skill in the field of heating system components for civil use, domestic hot water production and maintenance. Personnel must have the qualifications foreseen by current legislation.

Incorrect installation or improper maintenance can cause damage to persons, animals or objects for which the manufacturer is not responsible.

Before performing any cleaning or maintenance, disconnect the appliance from the energy mains by acting on the switch of the system and/or through the specific cut-off devices.

Not obstruct the terminals of the intake/exhaust ducts.

In case of failure and/or malfunctioning of the appliance, switch it off and do not try to repair it or intervene on it directly. Contact only personnel qualified in compliance with law.

Any repairs must be performed solely by personnel authorised by Ecoflam using original spare parts only. Failure to comply with the above can jeopardise the safety of the appliance.

To guarantee appliance efficiency and its correct operation, yearly maintenance must be performed by qualified personnel.

Should you decide not to use the appliance, parts entailing potential sources of hazard must be made safe.

Should the appliance be sold or transferred to a new owner or if you move and leave the appliance, always make sure that the instruction booklet accompanies it in order to be consulted by the new owner and/or installer.

Only original accessories must be used for all appliances with optionals or kits (including electric).

This appliance is intended solely for the use for which it was expressly designed. Any other use is to be considered improper and therefore dangerous.

2

TECHNICAL FEATURES AND DIMENSIONS

2.1 - TECHNICAL FEATURES

TRIMAX 3SC boilers are made up of an external shell (oval-shaped in models from 65-N to 840-N) (cylindrical-shaped in models from 1100-N to

1900-N) which houses the completely wet cylindrical furnace, where the first combustion gas pass takes place, and by a special tube and shell, used for the second and third pass.

A special manifold-distributor, positioned near the system's return and flow stub pipes, optimises water circulation and reduces stratification, providing a more even distribution of water temperature inside the boiler body.

The guided path of the combustion gas exploits the thermal exchange surfaces to a maximum and evenly balances strains on the materials.

The tube and shell is positioned on the top and hottest part of the boiler to reduce the temperature differential between combustion gas and primary fluid, thus limiting the formation of condensation, which causes corrosion and quick deterioration of traditional boilers.

TRIMAX 3SC boilers have been designed and approved to operate within an output range allowing them to perfectly adapt to the design heat output.

The construction fully complies with prescriptions laid down in EN 303 part 1.

The components of the pressurised part, such as sheets and pipes, are made in certified carbon steel, according to the EURONORM 25 and EURONORM 28 tables.

Welding devices and procedures are approved by TÜV (D) - UDT

(PL) - SA (S) and ISPESEL (I).

Up until model TRIMAX 3SC 380-N, the furnace is bonded to the rear tube plate.

For models TRIMAX 3SC 500-N ÷ TRIMAX 3SC 1900-N, the furnace is free to expand (it is only sustained by the front tube plate).

The boilers are equipped with an opening door on the right or left. The outer shell is covered with a glass wool insulation mattress 100 mm thick (80 mm for models TRIMAX 3SC 65-N and TRIMAX 3SC 85-N), in turn protected by a mineral fibre fabric. The top part of the shell is provided with hooks for lifting the boiler. Note: TRIMAX 3SC boilers are intended to operate with ON/OFF type GAS burners; as an alternative, they can be equipped with a dual-stage or modulating burner, as long as the minimum heat output in the first flame or in modulation does not drop below 60% the furnace load.

The boilers are provided with two ½" attachments for conduits with an inside diameter of 15 mm (suitable to house 3 bulbs each).

The shell has holes at the sides for the cable glands of the power, pumps, burner cables and those of any other auxiliary device.

2.2 - MAIN COMPONENTS

TRIMAX 3SC boilers are equipped with a cylindrical furnace in which the combustion gases, developed in the central flame, enter the return tube/s of the second pass and, having reached the front part, are sent through the door into the tubes of the third pass to reach the rear flue gas chamber and then the chimney.

The combustion chamber is always pressurised while the burner is operating, within the output range of the boiler.

For the value of this pressure, see the tables on pages 9÷13, at the column "Flue gas pressure drops".

The chimney must be calculated so that no positive pressure is detected on its base

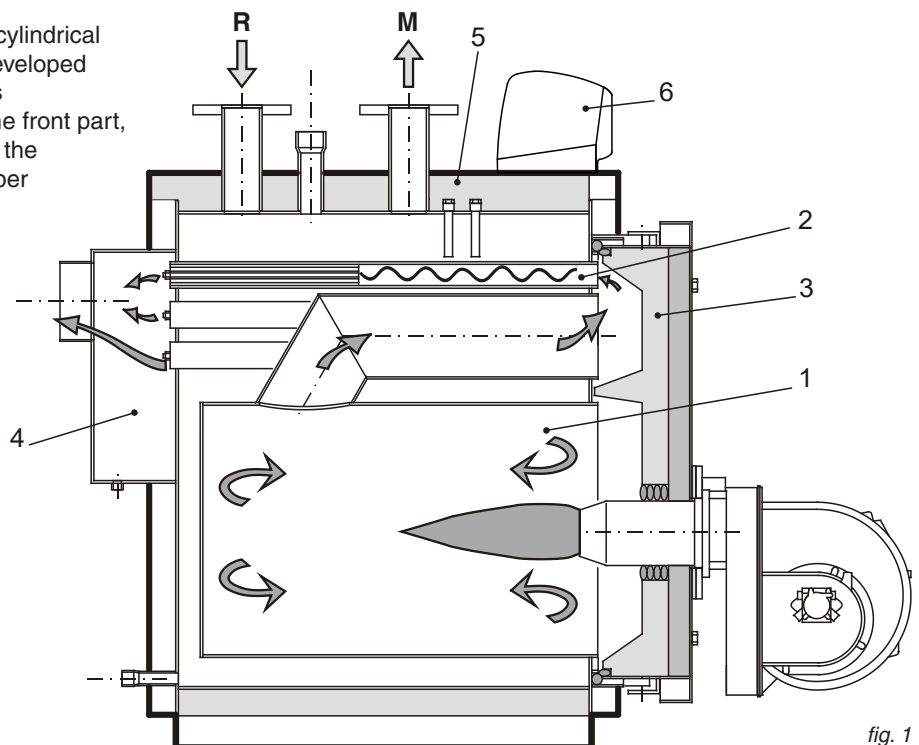

- 1 Furnace
- 2 Smoke pipes with smoke diverters
- 3 Door with flame sight glass
- 4 Smoke chamber
- 5 Body insulation
- 6 Panel board

fig. 1

Technical features and dimensions

2.3 - SMOKE TURBULATORS

TRIMAX 3SC boilers are designed to be used within an output range in order to improve seasonal efficiency and coupling with each heating system.

The heat output must therefore be adjusted upon commissioning, based on the guidelines of the Thermotechnical Engineer, and always within the range provided for each boiler on pages 9 - 13, by the burner technician who will determine the fuel flow rate.

In all cases, **make sure that the turbulators are positioned inside their respective smoke pipes.**

While operating the boiler at minimum output, the flue gas temperature must not be lower than 160°C.

If not, make sure that all the turbulators are inside the respective smoke pipes before contacting our After-Sales Service.

The burner must be commissioned under the responsibility of a qualified burner technician authorised by the manufacturer.

On that occasion, a complete operating report must be drafted.

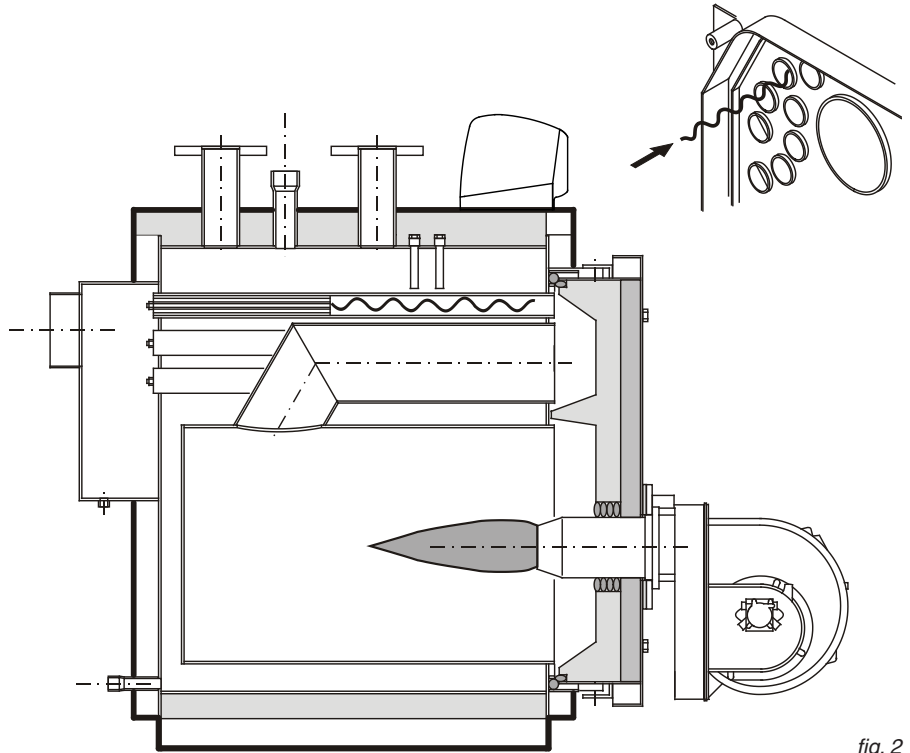

fig. 2

Technical features and dimensions

2.4 - DIMENSIONS - 65-N - 85-N

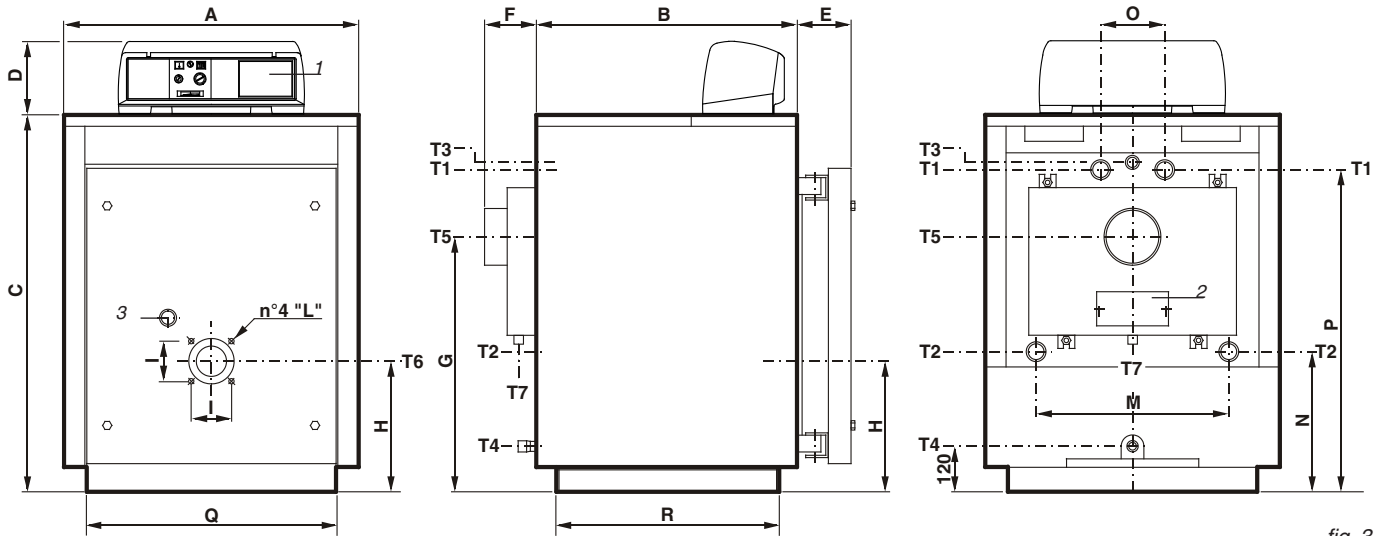

fig. 3

- 1 Panel board
- 2 Smoke chamber cleaning door
- 3 Flame sight glass
- T1 Central Heating flow

- T2 Central Heating return
- T3 Expansion vessel connection
- T4 Boiler drain
- T5 Chimney connection

- T6 Burner connection
- T7 Condensation drain

TRIMAX 3SC							CONNECTIONS							
Model	Nominal output kW	Nominal input kW	Boiler capacity l	Water pressure drops(**) m w.c.	Flue gas pressure drop mm w.c.	Maximum boiler working pressure bar	Weight kg	T1 ISO 7/1	T2 ISO 7/1	T3 ISO 7/1	T4 ISO 7/1	T5 Øi mm	T6 Ø mm	T7 Øe mm
65-N	55÷65	58,2÷69,2	131	0,04÷0,06	4,6÷6,4	6	315	Rp 1½	Rp 1	Rp ¾	150	132	40	
85-N	72÷85	76,1÷90,3	187	0,05÷0,07	5,4÷7,5	6	355	Rp 1½	Rp 1	Rp ¾	150	132	40	

TRIMAX 3SC		DIMENSIONS														
Model	A mm	B mm	C mm	D mm	E mm	F mm	G mm	H mm	I mm	I mm	M mm	N mm	O mm	P mm	Q* mm	R* mm
65-N	740	690	950	190	140	145	660	345	120	M8	470	310	190	846	660	590
85-N	740	950	950	190	140	145	660	345	120	M8	470	310	190	846	660	850

(*) Minimum dimensions for boiler room access.

(**) Pressure drops corresponding to a thermal drop of 15K.

DETAIL FOR DOOR DRILLING 65-N - 85-N

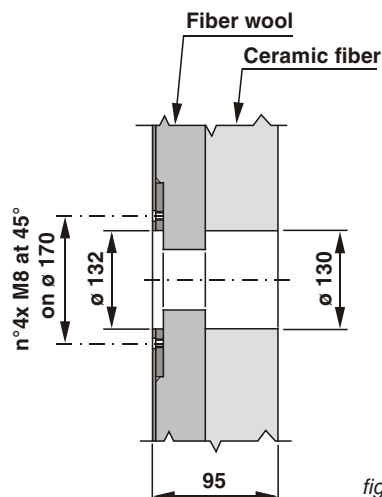
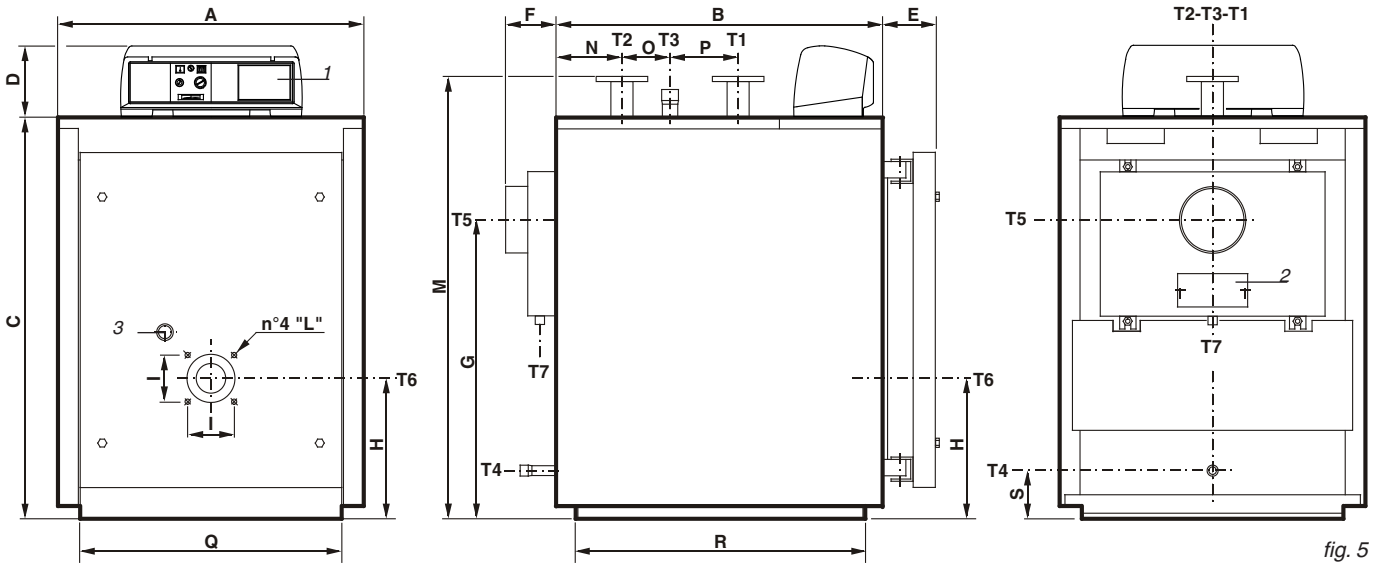

fig. 4

Technical features and dimensions

110-N÷380-N



- 1 Panel board
- 2 Smoke chamber cleaning door
- 3 Flame sight glass
- T1 Central Heating flow

- T2 Central Heating return
- T3 Expansion vessel connection
- T4 Boiler drain
- T5 Chimney connection

- T6 Burner connection
- T7 Condensation drain

fig. 5

TRIMAX 3SC	Nominal output	Nominal input	Boiler capacity	Water pressure drops(**)	Flue gas pressure drop	Maximum boiler working pressure	Weight	CONNECTIONS					
								T1 T2	T3	T4	T5	T6	T7
Modello	kW	kW	l	m w.c.	mm w.c.	bar	kg	UNI 2278 PN16	ISO 7/1	ISO 7/1	Øi mm	Ø mm	Øe mm
110-N	93÷109	98,1÷115,6	204	0,06÷0,08	7÷9,7	6	435	DN 50	Rp 1¼	Rp ¾	180	132	40
150-N	127÷150	133,6÷158,6	270	0,08÷0,10	11,2÷15,6	6	515	DN 50	Rp 1¼	Rp ¾	180	132	40
185-N	157÷185	164,9÷195,3	285	0,10÷0,18	14÷19,4	6	580	DN 65	Rp 1½	Rp ¾	180	180	40
225-N	191÷225	200,2÷237,1	322	0,17÷0,20	16,6÷23,1	6	640	DN 65	Rp 1½	Rp ¾	180	180	40
300-N	255÷300	265,9÷314,4	408	0,22÷0,35	20,5÷28,4	6	840	DN 80	Rp 2	Rp ¾	225	180	40
380-N	323÷380	336,8÷398,3	475	0,32÷0,53	23,6÷32,7	6	935	DN 80	Rp 2	Rp ¾	225	180	40

TRIMAX 3SC		DIMENSIONS															
Model	A	B	C	D	E	F	G	H	I	L	M*	N	O	P	Q*	R*	S
	mm	mm	mm	mm	mm	mm	mm	mm	mm	mm	mm	mm	mm	mm	mm	mm	mm
110-N	820	885	1082	190	140	145	748	380	120	M 8	1210	175	130	185	710	786	130
150-N	820	1145	1082	190	140	145	748	380	120	M 8	1210	175	390	185	710	1046	130
185-N	860	1080	1182	190	140	145	828	400	--	--	1310	215	210	250	750	981	130
225-N	860	1210	1182	190	140	145	828	400	--	--	1310	215	340	250	750	1111	130
300-N	890	1275	1352	190	140	145	928	440	--	--	1485	255	285	315	780	1177	125
380-N	890	1470	1352	190	140	145	928	440	--	--	1485	255	480	315	780	1372	125

(*) Minimum dimensions for boiler room access.

(**) Pressure drops corresponding to a thermal drop of 15K.

DETAIL FOR DOOR DRILLING 110-N - 150-N

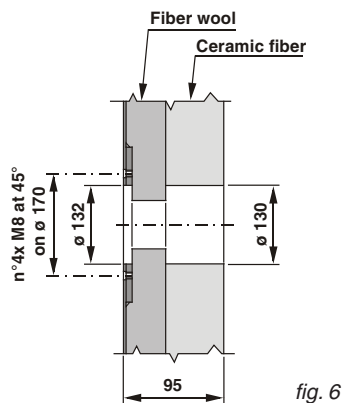

fig. 6

DETAIL FOR DOOR DRILLING 185-N - 225-N

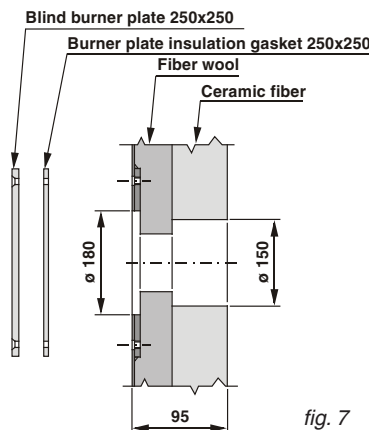

fig. 7

DETAIL FOR DOOR DRILLING 300-N - 380-N

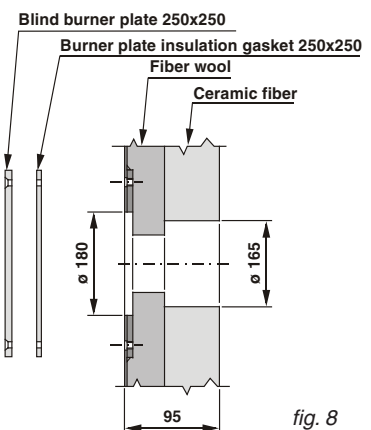

fig. 8

Technical features and dimensions

500-N÷730-N

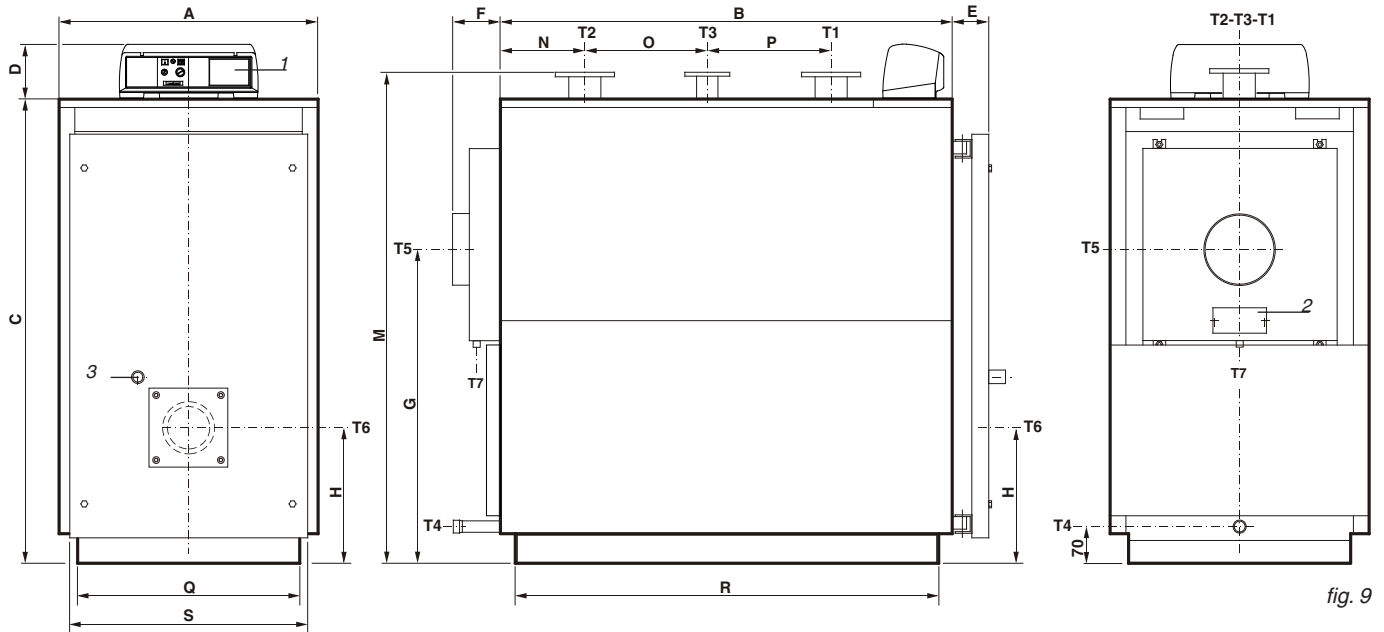

fig. 9

- | | | |
|-------------------------------|--------------------------------|-----------------------|
| 1 Panel board | T2 Central Heating return | T6 Burner connection |
| 2 Smoke chamber cleaning door | T3 Expansion vessel connection | T7 Condensation drain |
| 3 Flame sight glass | T4 Boiler drain | |
| T1 Central Heating flow | T5 Chimney connection | |

TRIMAX 3SC	Nominal output	Nominal input	Boiler capacity	Water pressure drops(**)	Flue gas pressure drop	Maximum boiler working pressure	Weight	CONNECTIONS					
								T1 T2	T3	T4	T5 Ø1	T6 Ø	T7 Øe
Model	kW	kW	l	m w.c.	mm w.c.	bar	kg	UNI 2278 PN16	UNI 2278 PN16	ISO 7/1	mm	mm	mm
500-N	425÷500	443,1÷524,1	656	0,10÷0,15	27,3÷37,8	6	1260	DN 100	DN 65	Rp 1	250	220	40
630-N	535÷630	557,8÷660,3	737	0,16÷0,23	33,5÷46,5	6	1375	DN 100	DN 65	Rp 1	250	220	40
730-N	620÷730	646,5÷765,2	807	0,23÷0,33	37,5÷52	6	1510	DN 100	DN 65	Rp 1	250	220	40

TRIMAX 3SC	DIMENSIONS														
	A	B	C	D	E	F	G	H	M*	N	O	P	Q*	R*	S*
Model	mm	mm	mm	mm	mm	mm	mm	mm	mm	mm	mm	mm	mm	mm	mm
500-N	920	1605	1645	190	135	195	1110	480	1735	298	435	440	790	1505	860
630-N	920	1800	1645	190	135	195	1110	480	1735	298	630	440	790	1790	860
730-N	920	1995	1645	190	135	195	1110	480	1735	298	825	440	790	1895	860

(*) Minimum dimensions for boiler room access.

(**) Pressure drops corresponding to a thermal drop of 15K.

DETAIL FOR DOOR DRILLING 500-N÷730-N

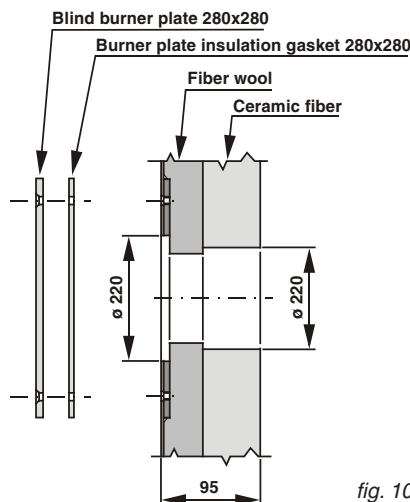

fig. 10

Technical features and dimensions

840-N

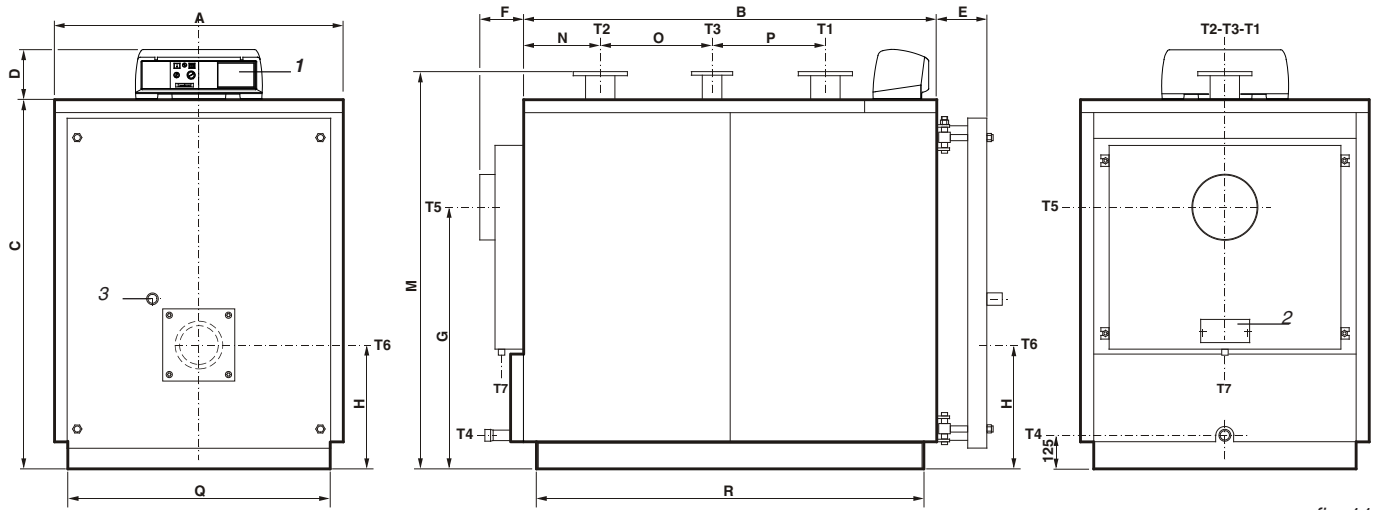

fig. 11

- 1 Panel board
- 2 Smoke chamber cleaning door
- 3 Flame sight glass
- T1 Central Heating flow

- T2 Central Heating return
- T3 Expansion vessel connection
- T4 Boiler drain
- T5 Chimney connection

- T6 Burner connection
- T7 Condensation drain

TRIMAX 3SC								CONNECTIONS						
Model	Nominal output kW	Nominal input kW	Boiler capacity l	Water pressure drops(**) m w.c.	Flue gas pressure drop mm w.c.	Maximum boiler working pressure bar	Weight kg	T1 T2	T3	T4	T5 Øi mm	T6 Ø mm	T7 Øe mm	
840-N	714÷840	744,5÷880,5	932	0,35±0,52	41,4±57,3	6	1650	UNI 2278 PN16 DN 100	UNI 2278 PN16 DN 65	ISO 7/1 Rp 1¼	250	270	40	

TRIMAX 3SC														
DIMENSIONS														
Model	A mm	B mm	C mm	D mm	E mm	F mm	G mm	H mm	M* mm	N mm	O mm	P mm	Q* mm	R* mm
840-N	1122	2115	1432	190	195	195	1025	480	1540	298	945	440	1020	2014

(*) Minimum dimensions for boiler room access.

(**) Pressure drops corresponding to a thermal drop of 15K.

DETAIL FOR DOOR DRILLING 840-N

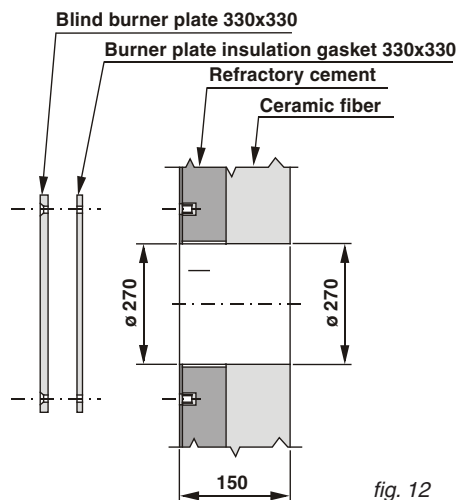

fig. 12

Technical features and dimensions

1100-N÷1900-N

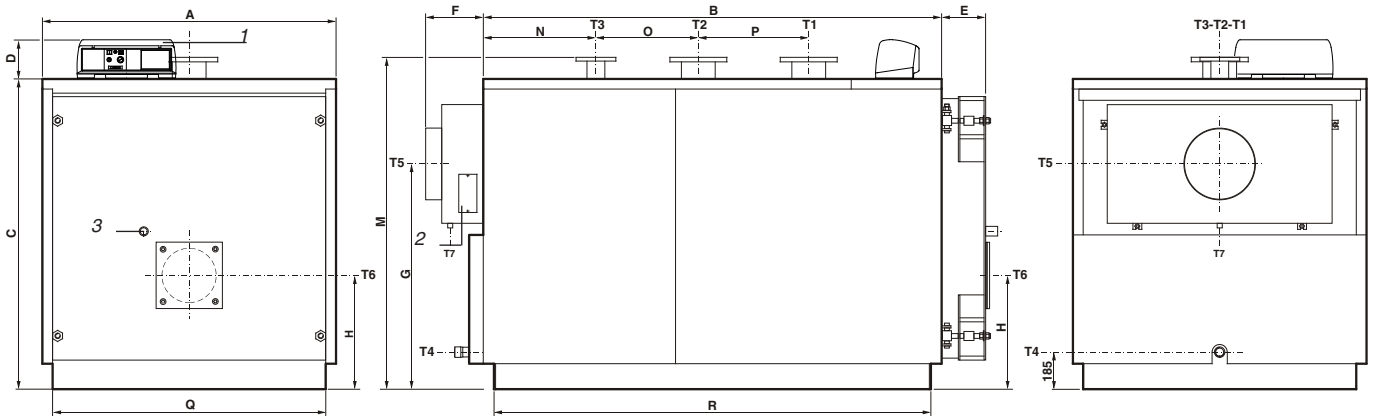

fig. 13

- 1 Panel board
- 2 Smoke chamber cleaning door
- 3 Flame sight glass
- T1 Central Heating flow

- T2 Central Heating return
- T3 Expansion vessel connection
- T4 Boiler drain
- T5 Chimney connection

- T6 Burner connection
- T7 Condensation drain

TRIMAX 3SC	Nominal output	Nominal input	Boiler capacity	Water pressure drops(**)	Flue gas pressure drop	Maximum boiler working pressure	Weight	CONNECTIONS					
								T1 T2	T3	T4	T5 Øi	T6 Ø	T7 Øe
Model	kW	kW	l	m w.c.	mm w.c.	bar	kg	UNI 2278 PN16	UNI 2278 PN16	ISO 7/1	mm	mm	mm
1100-N	935÷1100	974,9÷1153	1580	0,15÷0,21	48,8÷67,5	6	2530	DN 150	DN 80	Rp 1½	350	270	40
1320-N	1122÷1320	1169,9÷1383,6	1791	0,21÷0,30	53,7÷74,3	6	3065	DN 150	DN 80	Rp 1½	350	270	40
1600-N	1360÷1600	1418,1÷1677,1	2297	0,20÷0,28	58,9÷81,6	6	4005	DN 175	DN 100	Rp 1½	400	285	40
1900-N	1615÷1900	1684÷1991,5	2496	0,27÷0,39	63,6÷88,1	6	4230	DN 175	DN 100	Rp 1½	400	285	40

TRIMAX 3SC		DIMENSIONS												
Model	A	B	C	D	E	F	G	H	M*	N	O	P	Q*	R*
mm	mm	mm	mm	mm	mm	mm	mm	mm	mm	mm	mm	mm	mm	mm
1100-N	1462	2282	1542	190	230	290	1120	565	1650	561	510	550	1360	2176
1320-N	1462	2652	1542	190	230	290	1120	565	1650	561	880	550	1360	2546
1600-N	1622	2692	1702	190	260	290	1245	605	1810	661	670	700	1520	2590
1900-N	1622	3014	1702	190	260	290	1245	605	1810	662	990	700	1520	2910

(*) Minimum dimensions for boiler room access.

(**) Pressure drops corresponding to a thermal drop of 15K.

DETAIL FOR DOOR DRILLING 1100-N - 1320-N

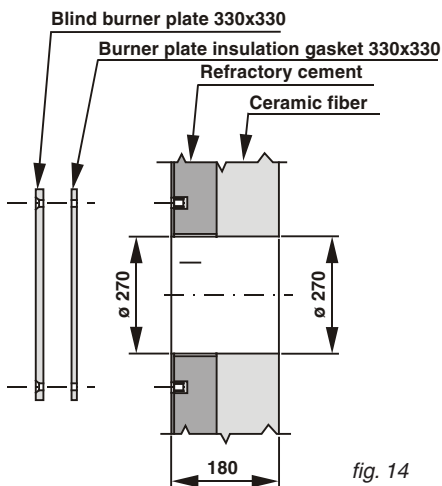

fig. 14

DETAIL FOR DOOR DRILLING 1600-N - 1900-N

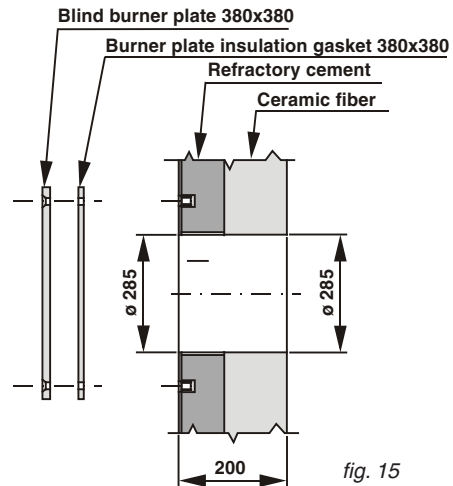

fig. 15

2.5 - OPERATING DATA ACCORDING TO UNI 10348

	65-N	85-N	110-N	150-N	185-N	225-N	300-N	380-N
GAS-FIRED								
Nominal heat output	kW	55÷65	72÷85	93÷109	127÷150	157÷185	255÷300	323÷380
Nominal heat input	kW	58,2÷69,2	76,1÷90,3	98,1÷115,6	133,6÷158,6	164,9÷195,3	200,2÷237,1	336,8÷398,3
Heat efficiency at nominal load (100%)	%	94,4÷93,9	94,6÷94,1	94,8÷94,3	95,2÷94,7	95,4÷94,9	95,9÷95,4	95,9÷95,4
Heat efficiency at 30% load	%	94,6÷94,1	94,8÷94,3	95,2÷94,7	95,4÷94,9	95,6÷95,1	96,1÷95,6	96,1÷95,6
Number of stars (according to 92/42 EEC)	n.	3	3	3	3	3	3	3
Combustion efficiency at nominal load (100%)	%	95,9÷95,1	95,9÷95,2	96÷95,2	96÷95,3	96,1÷95,4	96,3÷95,6	96,3÷95,6
Heat loss at casing (min. - max.)	%	1,4÷1,2	1,3÷1,1	1,2÷0,9	0,9÷0,7	0,8÷0,6	0,9÷0,7	0,4÷0,2
Heat loss at chimney with burner on (min.-max.)	%	4,1÷4,9	4,1÷4,8	4÷4,8	4÷4,7	3,9÷4,6	3,7÷4,4	3,7÷4,4
Heat loss at chimney with burner off (min.-max.)	%	0,1÷0,1	0,1÷0,1	0,1÷0,1	0,1÷0,1	0,1÷0,1	0,1÷0,1	0,1÷0,1
Flue gas temperature if-ta (min.-max.)	°C	85÷100	84÷99	83÷98	82÷97	80÷95	76÷91	75÷90
CO ₂ content	%	9,8÷9,8	9,8÷9,8	9,8÷9,8	9,8÷9,8	9,8÷9,8	9,8÷9,8	9,8÷9,8
Flue gas mass flow rate (min.-max)	kg/h	87,6÷104	114,5÷135,8	147,5÷173,8	200,8÷238,5	247,8÷293,5	300,9÷356,4	399,7÷472,7
GAS-FIRED								
Nominal heat output	kW	425÷500	535÷630	620÷730	714÷840	935÷1100	1122÷1320	1360÷1600
Nominal heat input	kW	443,1÷524,1	557,8÷660,3	646,5÷765,2	744,5÷880,5	974,9÷1153	1169,9÷1383,6	1418,1÷1677,1
Heat efficiency at nominal load (100%)	%	95,9÷95,4	95,9÷95,4	95,9÷95,4	95,9÷95,4	95,9÷95,4	95,9÷95,4	95,9÷95,4
Heat efficiency at 30% load	%	96,1÷95,6	96,1÷95,6	96,1÷95,6	96,1÷95,6	96,1÷95,6	96,1÷95,6	96,1÷95,6
Number of stars (according to 92/42 EEC)	n.	--	--	--	--	--	--	--
Combustion efficiency at nominal load (100%)	%	96,3÷95,6	96,3÷95,6	96,3÷95,6	96,3÷95,6	96,3÷95,6	96,3÷95,6	96,3÷95,6
Heat loss at casing (min. - max.)	%	0,4÷0,2	0,4÷0,2	0,4÷0,2	0,4÷0,2	0,4÷0,2	0,4÷0,2	0,4÷0,2
Heat loss at chimney with burner on (min.-max.)	%	3,7÷4,4	3,7÷4,4	3,7÷4,4	3,7÷4,4	3,7÷4,4	3,7÷4,4	3,7÷4,4
Heat loss at chimney with burner off (min.-max.)	%	0,1÷0,1	0,1÷0,1	0,1÷0,1	0,1÷0,1	0,1÷0,1	0,1÷0,1	0,1÷0,1
Flue gas temperature if-ta (min.-max.)	°C	75÷90	75÷90	75÷90	75÷90	75÷90	75÷90	75÷90
CO ₂ content	%	9,8÷9,8	9,8÷9,8	9,8÷9,8	9,8÷9,8	9,8÷9,8	9,8÷9,8	9,8÷9,8
Flue gas mass flow rate (min.-max)	kg/h	666,1÷787,8	838,5÷992,6	971,7÷1150,2	1119,1÷1323,5	1465,5÷1733,1	1758,6÷2079,7	2131,6÷2520,9
								2531,3÷2993,5

3

**INSTALLATION
INSTRUCTIONS**

3.1 - GENERAL WARNINGS



ATTENTION!
This boiler is intended solely for the use for which it was expressly designed. Any other use is to be considered improper and therefore dangerous. This boiler heats water at a temperature lower than the atmospheric pressure boiling temperature.



ATTENTION!
The appliances are designed to be installed inside suitable rooms or technical spaces only. The appliances cannot be installed or operate outdoors. Outdoor installation can cause malfunctioning and be dangerous. Choose specifically designed appliances for outdoor installation.



Before connecting the boiler, have professionally qualified personnel:

- a) Thoroughly wash all the piping of the system to remove any residue or impurities which could jeopardise proper operation of the boiler.
- b) Check that boiler is set up to operate with the available type of fuel.
This can be seen written on the package and on the technical feature plate.
- c) Check that the chimney/flue has an appropriate draught, without any bottlenecks, and that no exhausts from other appliances are inserted, unless the flue has been implemented to accommodate several utilities according to specific standards and prescriptions in force. Only after this check can the fitting between the boiler and chimney/flue be mounted.



ATTENTION!
In rooms with the presence of aggressive vapours or dust, the appliance must operate independently from the air inside the installation room!



ATTENTION!
The appliance must be installed by a qualified technician with the technical-professional requirements according to law which, under his own responsibility, guarantees compliance with standards according to good practice rules.



The boiler must be connected to a central heating system and/or domestic hot water supply network compatible with its efficiency and output.

3.2 - INSTALLATION STANDARDS

The appliance must be installed in compliance with the instructions provided in this manual.

It must be installed by a professionally qualified technician, **who shall assume the responsibility of respecting all local and/or national laws published in the official journal, as well as applicable technical standards.**

TRIMAX 3SC is a steel boiler which can be combined with air-blown burners fired by gas of category **II2H3+**.

Contact the gas supplying company before installing the appliance.

Directives concerning boiler rooms, building regulations and combustion heating provisions in the country of installation must also be respected.

The appliance must be installed, commissioned and undergo maintenance according to the current "state-of-the-art". This also holds for the hydraulic system, the flue exhaust system and the installation room.

3.3 - HANDLING



The boiler can be handled easily, lifting it by means of upper hook/s or shifting it on rollers underneath the sturdy base longerons. If necessary for clearance purposes, the door and

the smoke chamber can be removed to make it easier to enter the boiler room.

3.4 - POSITIONING IN BOILER ROOM

The boiler must be installed in compliance with standards and prescriptions in force.

The room must be well ventilated by openings with a total surface no less than 1/30 the surface of the boiler room, with a minimum of 0.5 m².

The ventilation openings must be permanent, communicate directly with the outside and be positioned high or low according to standards in force.

The location of the ventilation openings, the fuel supply circuits, electric energy supply and lighting must comply with current legal provisions in relation to the type of fuel used.

It is recommended to install the boiler as close to the chimney connection as possible.

To make it easier to clean the smoke circuit, in front of the boiler, there must be a free space no less than the length of the boiler body and, in any case, never less than 1300 mm. Check that with the door opened 90°, the distance between the door and the adjacent wall is at least the length of the burner.

The boiler can be placed directly on the floor as it is equipped with a base.

However it is useful to provide a flat, level cement plinth capable of bearing the weight of the boiler full of water.

When positioned on the plinth, the dimensions must be at least **Q x R** (see dimensions table).

When installation has been performed, the boiler must be perfectly horizontal and stable (to reduce vibrations and noise).

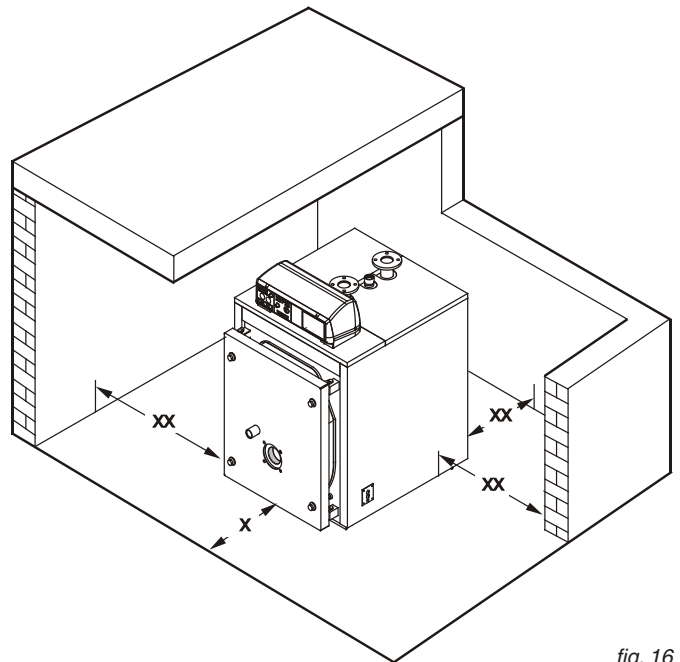

fig. 16

*x = not less than the length of the boiler body (dimensions in mm); in any case, never less than 1300 mm.
xx = see instructions to the side.*

3.5 - BURNER

The burners operating with the TRIMAX 3SC boilers must have the EC certification and comply with:

- Gas appliance directive (90/396/EEC).
- EMC Directive - Electromagnetic Compatibility (89/336/EEC).

They must also be approved according to the specifications:

- UNI EN 676 - air-blown burners for gaseous fuel.
- Efficiency Directive (92/42 EEC).

3.5.1 - CHOOSING THE BURNER

The correct choice and adjustment of the burner are fundamental for optimal operation of the boiler and therefore must be done carefully and not underestimated.

The burner must be chosen verifying that its firing rate (fuel capacity - combustion chamber pressure) is compatible with the same features declared for the boiler.

Remember that pressure drops on the flue side of the boiler, namely combustion chamber backpressure, refer to zero pressure at the base of the chimney.

It is also recommended that the burner blast tube be no shorter than the minimum dimension shown in the following table and that the flame which must be implemented be suitable for the characteristics of the combustion chamber.

In order to take advantage of the whole heat exchange surface of the blind bottom furnaces, use burners capable of providing a "long and narrow" flame in any operating condition, namely even at the minimum output when controlling two or more stages or modulating.

Flames which are too short cause overheating in the front of the furnace and combustion products, not sufficiently cooled, entering the smoke pipes at too high temperatures can seriously damage the generator.

The manufacturing companies of the burners can supply the dimensions of the flames which their appliances develop,

Installation instructions

especially those approved based on the standards indicated above.

Further information is provided in the chapter "Commissioning".

BOILER TYPE	$\varnothing A$ mm	L mm
65-N - 85-N	132	180
110-N - 150-N	132	180
185-N - 225-N	180	180
300-N - 380-N	180 </td <td>200</td>	200
500-N ÷ 730-N	220	230
840-N	270	280
1100-N - 1320-N	270	320
1600-N - 1900-N	285	350

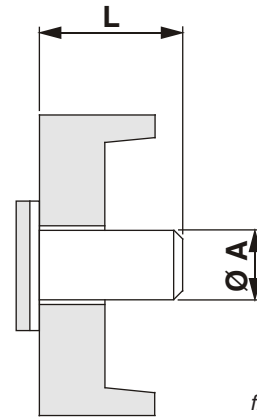

fig. 17

DIMENSIONS OF BURNER BLAST TUBE

3.5.2 - INSTALLING THE BURNER



Before assembling the burner, check the position of the turbulators inside the tubes: each tube must be provided with its own turbulator and this must be positioned as shown in the figure on page 8.

The burner must be mounted to the door of the boiler guaranteeing perfect sealing of the combustion products. The burner is supplied with a **piece of ceramic fiber cord which must be placed on the blast tube of the burner to fully seal the space between the blast tube and the slot in the door.** Make sure that no gaps remain between the blast tube and the slot on the refractory material inside the door.

Should a cone larger than the diameter of the blast tube be mounted, it must be removed before mounting the burner on the support plate and put back afterwards.

With the burner mounted, check that the electric cables are long enough to allow the door to open 90°.

For gas-fired burners, flexible hoses cannot be used for connections. Therefore it must be possible to disconnect the final section of the gas addition tube by means of a threaded or flanged joint.

3.6 - CONNECTING FLAME SIGHT GLASS TO BURNER

The flame sight glass is provided with a 1/8" threaded connection (pos. 1) upon which a 9 mm pressure test nipple is mounted. It can be used with a silicon tube to measure the backpressure in the combustion chamber.

In place of this test nipple, which must be kept, an appropriate fitting will be mounted to connect the flame sight glass directly to the pressure chamber downstream the burner fan by means of a copper tube (pos.2).

The air blown by the fan will conveniently cool the sight glass and keep it from blackening.

If the cooling tube is not connected to the sight glass, it could break.



ATTENTION: the flame sight glass can be very hot; therefore pay the utmost attention.

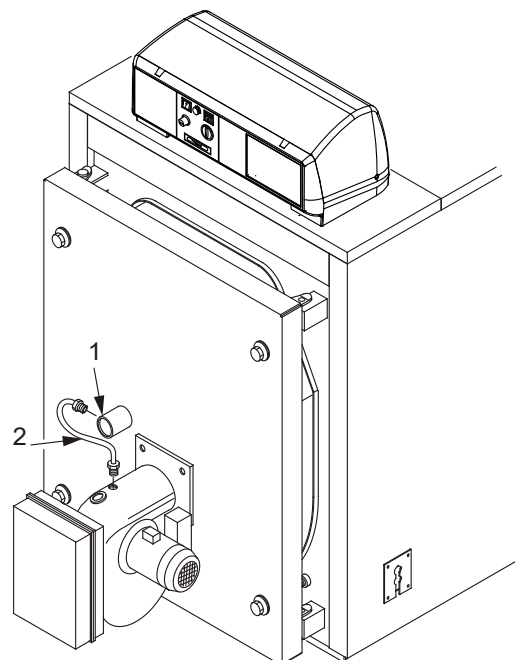

fig. 18

3.7 - FURNACE DOOR: ADJUSTMENT, OPENING AND CLOSING

IMPORTANT

- The door of the boiler must be opened when it is cooled off to avoid damaging the fibre due to thermal shock.
- The insulation fibre of the door can show cracks after a short time of operation; this however does not reduce its insulation capacity nor jeopardise its lifespan.
- The door fibre is easy to replace and is covered by a two-year warranty.

3.7.1 - "65-N - 85-N" BOILERS

For all these models, the door is hinged and fixed according to the layout in fig. 19. In these cases, the door is mounted with four equal hinges: the two on the left side, with the pin inserted, are normally used as rotation hinges (from right to left), while the two on the right side are used as closing hinges; the door is then secured with 4 screws.

It will be exactly the opposite when the door is opened from the left to the right.

To invert rotation, just move the pins to the opposite side.

The following adjustments can be made on the door of these boiler models:

- A) Vertical adjustment:** only by inserting suitably thick washers below the hinge which the door turns on.
- B) Crosswise rotation:** loosening the hinges fixed on the front plate of the boiler and moving them sideways.
- C) Axial rotation:** screwing different tightening screws.

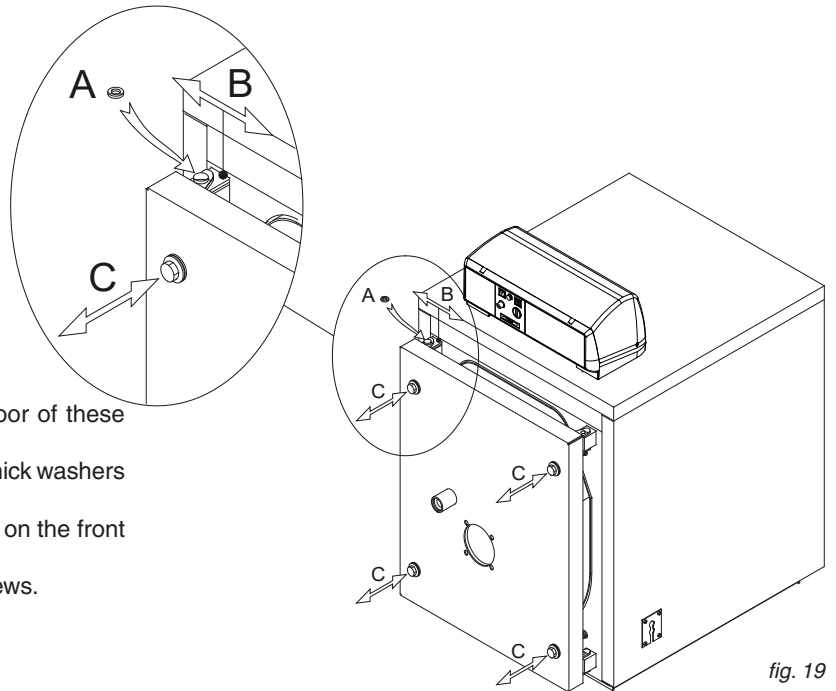

fig. 19

3.7.2 - "110-N ÷ 380-N" BOILERS

For all these models, the door is hinged and fixed according to the layout in fig. 20.

In these cases, the two hinges on the left are normally used as rotation hinges (from right to left), while the two on the right side are used as closing hinges.

It will be exactly the opposite when the door is opened from the left to the right.

To invert rotation, just move the rear locknuts to the opposite side.

The following adjustments can be made on the door of these boiler models:

- A) Vertical adjustment:** only by inserting suitably thick washers below the hinge which the door turns on.
- B) Crosswise rotation:** loosening the hinges fixed on the front plate of the boiler and moving them sideways.
- C) Axial rotation:** screwing different tightening screws.

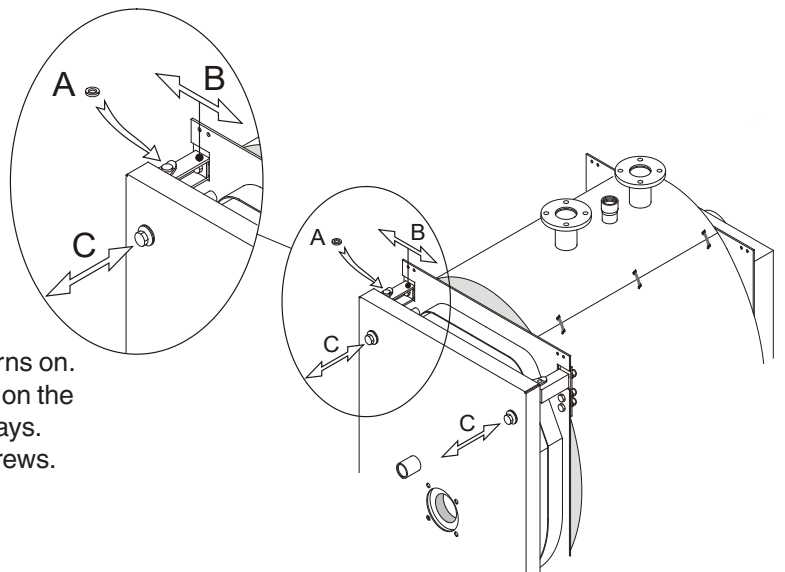

fig. 20

Installation instructions

3.7.3 - "500-N ÷ 730-N" BOILERS

For all these models, the door is hinged and fixed according to the layout in fig. 21.

In these cases, the two hinges on the left are normally used as rotation hinges (from right to left), while the two on the right side are used as closing hinges.

It will be exactly the opposite when the door is opened from the left to the right.

To invert rotation, just move the rear locknuts to the opposite side. The following adjustments can be made on the door of these boiler models:

- A) Vertical adjustment:** only by inserting suitably thick washers below the hinge which the door turns on.
- B) Crosswise rotation:** loosening the hinges fixed on the front plate of the boiler and moving them sideways.
- C) Axial rotation:** screwing different tightening nuts.

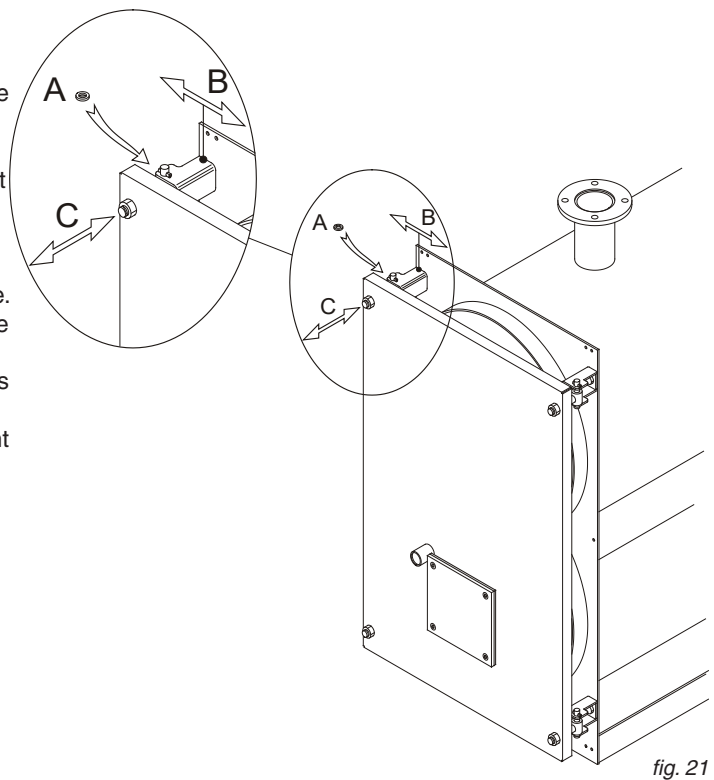

fig. 21

3.7.4 - "840-N ÷ 1900-N" BOILERS

For all these models, the door is hinged and fixed according to the layout in fig. 22.

In these cases, the two hinges on the left are normally used as rotation hinges (from right to left), while the two on the right are used as closing hinges.

It will be exactly the opposite when the door is opened from the left to the right.

To invert rotation, just move the rear locknuts to the opposite side. The following adjustments can be made on the door of these boiler models:

- A) Vertical adjustment:** by acting on the nut of the upper hinge pin which the door turns on.
- B) Crosswise rotation:** loosening the hinges fixed on the front plate of the boiler and moving them sideways.
- C) Axial rotation:** screwing different tightening nuts.

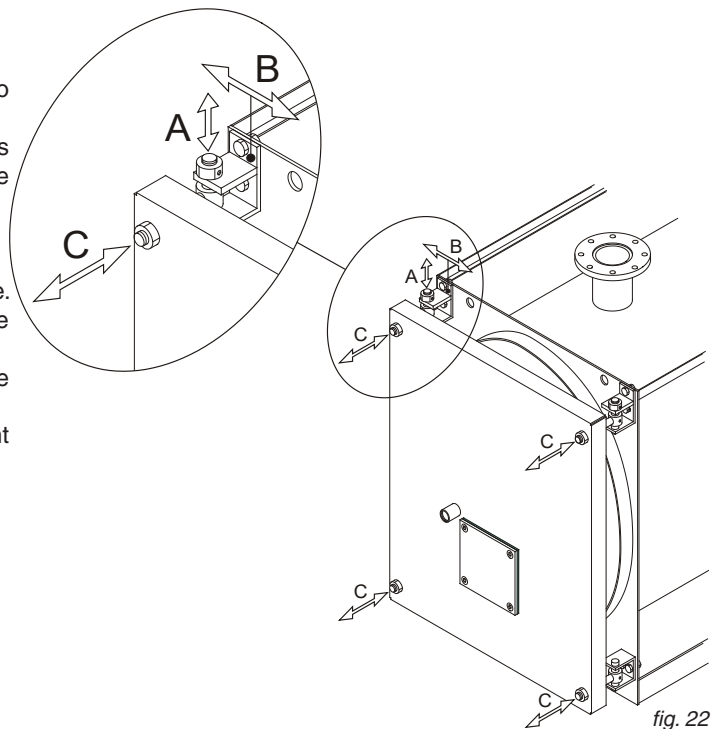

fig. 22

3.7.5 - IMPORTANT NOTE

Before opening the door of the furnace, take the following safety measures:

- Close the fuel supply (diesel oil or gas) to the burner.
- Cool the boiler off by having water circulate and then disconnect electrical power.

- Place a sign on the boiler with the following text: **DO NOT USE, BOILER MAINTENANCE UNDERWAY, OUT OF SERVICE.**

3.8 - CONNECTING FLUE EXHAUST PIPE

To connect the flue gas exhaust pipe, local and national standards must be respected.

The TRIMAX 3SC boiler can be attached to the chimney in different ways; straight pipes or elbows can be used to exit from the rear, on the left, on the right, or else vertically to enter into the flue at a higher level.

It is recommended to insulate the pipe connecting to the chimney to reduce heat loss and noise.

Along the section connecting the boiler to the flue there must be suitable points for measuring flue gas temperature and analysing combustion products.



Use only exhaust pipes suitable for the type of fuel used.

The supplier will have no contractual or extra-contractual liability for damage caused due to incorrect installation and use and anyway failure to comply with the instructions provided by the manufacturer.

When performing replacement installations, ALWAYS replace the flue gas exhaust accessory as well. The flue must comply with standards in force.

3.9 - DRAINING CONDENSATION

CONDENSATION UPON COMMISSIONING

While the boiler is reaching the operating temperature, a good amount of condensation can be formed due to the low temperature of the flue gas.

In these conditions, it could be useful to have the condensation drained into the sewer. For this purpose, the smoke chamber is equipped with an attachment which the exhaust pipes will be connected to according to the following notes

When the operating temperature has been reached - see notes in chap. 3.22 "COMMISSIONING" - it is important to check whether more condensation has been formed.

This can be checked by direct inspection through the cleaning doors of the smoke chamber.

If not, after having verified the actual fuel flow rates, the operating temperature should be increased.

The condensation drainage in the sewer must be:

- implemented as to prevent releasing gaseous combustion products into the environment or sewer (siphoning);
- dimensioned and implemented to allow the correct outflow of liquid waste preventing any leakage;
- installed in such a way to prevent liquid from freezing in the intended operating conditions;

- mixed for example with household wastewater (washer, dishwasher drainage, etc.) for the most part with basic pH in order to form a buffer solution to then be introduced in the sewer system.

Condensation must not stagnate in the combustion product drainage system (for this reason the evacuation duct must slope at least 30 mm/m towards the drain) except for a liquid seal, present in the drainage siphon for the evacuation of combustion products (which must be filled after assembly and must remain at least 25 mm high with the boiler running - see fig. 23).

Do not discharge condensation through gutter drainpipes due to the risk of turning into ice and the deterioration of the materials usually used to make the drainpipes (consult local hygiene regulations).

The drain fitting must be visible.

Due to the acidity level of the condensation (pH from 3 to 5) only suitable plastic materials must be used for the drain piping (special optional kits with neutralizer salts for acid condensation are available).

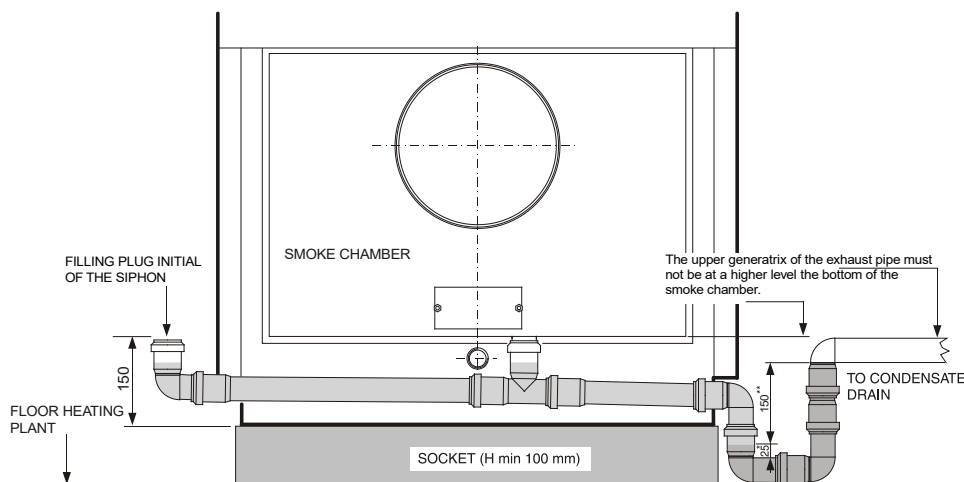

fig. 23

* Minimum safety siphon set by the standard.

** Minimum head with boiler running at maximum power.

If you do not want to or cannot create a plinth, the boiler can be mounted at ground level and a sump at least 100 mm deep can be made to house the siphon.

Installation instructions

3.10 - CONNECTING BOILER TO SYSTEM



Attention!

Before connecting the boiler to the heating system, thoroughly clean the piping with an appropriate product in order to eliminate metallic residue from processing and welding, oil and grease which could be present and which, reaching the boiler, could alter its functioning.

Do not use solvents to wash the system as they could damage the system and/or its components.

Failure to comply with the instructions of the following manual can cause damage to persons, animals and objects for which the manufacturer cannot be held responsible.



Attention!

Make sure that there are no mechanical tension points while connecting the pipes to avoid the risk of leakage!

Heating flow and return pipes must be connected to the boiler at the respective fittings as indicated on pages 9, 10, 11, 12 and 13.

For the dimensioning of the heating circuit pipes, you must take into account pressure drops caused by radiators, thermostatic valves, radiator stopping valves and by the configuration of the system.

The laying of the pipes must be designed taking every necessary precaution to avoid air pockets and to facilitate continuous degassing of the system.



Make sure that the pipes of the water and heating system are not used as earthing electrodes of the electric or telephone system.

They are absolutely not suitable for this type

of use. Serious damage could result for the piping, boiler and radiators in a short amount of time.

Heating system safety valve drainage

Provide a drain pipe with a funnel and a siphon leading to an appropriate drainage at the heating safety valve. This drainage must be controlled on sight.

Attention!



If this precaution is not taken, triggering of the safety valve can cause damage to persons, animals and objects for which the manufacturer cannot be held responsible.

Connection of expansion vessel



TRIMAX 3SC boilers are suitable for operating with forced water circulation both with the expansion vessel opened or closed.

An expansion vessel is always necessary to compensate the increase in water volume due

to heating.

The connection pipes of the expansion vessel will start from the T3 attachment (see DIMENSIONS TABLES) and must have no shut-off valve.

Connection of filling /drain tap

A specific tap can be connected to the T4 attachment at the rear of the boiler for filling and draining.

3.10.1 - RECIRCULATION PUMP

TRIMAX 3SC boilers must always operate with forced water circulation and a minimum return temperature of 50°C.

It is therefore recommended to use a recirculation pump, which also has an anti-condensation function, installed between the flow and return connections upstream the mixer valve.

This pump should be dimensioned according to the formula:

$$Q = P \times 22$$

where **Q** = Flow rate in l/hr

P = Nominal output of boiler in kW

and **head** 1÷2 m H₂O

3.11 - FILLING THE SYSTEM



Attention!

Do not mix the heating water with incorrect concentrations of antifreeze or anti-corrosion substances! This could damage the gaskets and cause noise during operation.

Ecoflam will not be held liable for damage to persons, animals or objects due to failure to comply with the instruction above.

When all system connections have been completed, the circuit can be filled.

This operation must be performed carefully, respecting the

Installation instructions

following phases:

- Open the radiator air release valves.
- Open the filling tap gradually, making sure that the automatic air release valves installed on the system work properly.
- Close the radiator air release valves as soon as water comes out.
- Check the pressure gauge until pressure reaches approximately 1 bar.
- Close the filling tap and bleed air once again through the radiator air release valves.
- Make sure that all the connections are watertight.
- After commissioning the boiler and bringing the system to the operating temperature, stop the pumps and repeat the air bleed operations.
- Let the system cool off and, if necessary, return the water pressure to 1 bar.

NOTE

The water pressure in the heating system must not be drop below 1 bar; open the filling tap on the boiler when pressure is too low.



This operation must be performed with the system cool.

NOTE



If the boiler was without electric power, after a certain idle period, the pump could be blocked. Before turning on the main switch, the pump must be unblocked by operating as follows:

Introduce a screwdriver in the hole below the protective screw in the centre of the pump intended for this purpose and turn the pump shaft clockwise. After having unblocked the pump, tighten the protective screw and make sure there is no water leakage.

ATTENTION!

After removing the protective screw, a small amount of water could leak out. Dry off all wet surfaces before powering the boiler.



3.12 - CONNECTING GAS



Danger!

The gas connection must be carried out only by a qualified installer who must respect and apply that foreseen by relevant laws in force in the local prescriptions of the supply company. Incorrect installation can cause damage to persons, animals and objects for which the manufacturer cannot be held responsible.



Before installation, we recommend a thorough inner cleaning of all fuel adduction piping to remove any residue which could jeopardise proper operation of the boiler.



Attention!

Make sure that there are no mechanical tension points while connecting gas to avoid the risk of leakage!



Perceiving the smell of gas:

- Do not turn electric switches on or off, use a telephone or any other object which can create sparks.
- Immediately open doors and windows to create an air current to air out the room;
- Shut the gas cocks.
- Request the intervention of professionally qualified personnel.



As a precaution against gas leaks, we recommend installing a monitoring and protection system consisting in a gas leak detector coupled with a shut-off solenoid valve on the gas feed line.

The supply pipes must have a cross-section sufficient for the flow rate of the burner.

You should nonetheless comply with the "General installation regulations".

Before commissioning an internal gas distribution system and therefore before connecting it to the gas meter, check its sealing carefully.

If any part of the system is out of sight, the sealing test must be done before the pipes are covered.

Before connecting the appliances, the system must be tested with air or inert gas at a pressure of at least 100 mbar.

The following operations and checks must also be performed while commissioning the system:

- Open the meter and air release valve to bleed the air from the piping of the appliances, proceeding one appliance after another.
- With the appliances closed, check that there are no gas leaks. The pressure gauge must show no pressure drop during the second quarter of an hour from the start of the test. Gas leaks must be found with a soapy solution or similar product and eliminated. Never look for gas leaks with an open flame.

Installation instructions

3.13 - PACKAGING

TRIMAX 3SC boilers are supplied complete with the door and smoke chamber assembled, while the casing and insulation are included in separate cardboard packs.

The panel and accessories are inside the combustion chamber. Before starting installation, make sure that the length and width of the boiler body received correspond respectively to the dimensions **M**, **Q** and **R** of the boiler you have ordered, provided on the previous tables, and that the boxes containing the casing, or part of it, are marked as in the table at the bottom of the page.

The casing of boilers from 65-N to 380-N, complete with insulation mattresses, **is contained in one box.**

The casing of boilers from 500-N to 840-N is contained in 3 boxes.

The casing of boilers from 1100-N to 1600-N is contained in 4 boxes.

The casing of the 1900-N boilers is contained in 5 boxes.

In addition to the panel board packed in its own box, the following accessories are found in the combustion chamber:

- 1 box containing hydraulic connection flanges, with relative gaskets and bolts (where included), cylindrical brush to clean pipes.
- Cleaning brush extensions.
- Turbulator extractor.
- Ceramic fibre cord to insulate between burner blast tube and door.

Upon reception, make sure that the supply is complete and



undamaged.



Keep the packaging material (cardboard box, straps, plastic bags, etc.) **out of the reach of children as they are potential sources of danger.**

Ecoflam will not be held liable for damage to persons, animals or objects due to failure to comply with the instruction above.

The document envelope contains:

- System manager operating instructions.
- Installation and maintenance instruction booklet.
- Warranty.
- Local ventilation requirements label.

N.B. For models from **65-N** to **85-N** (ref. fig. 24 and 25), the casing and insulation are contained in 1 box marked:

50085(65-N)
50086(85-N)

N.B. For models from **110-N** to **380-N** (ref. fig. 26 and 27), the casing and insulation are contained in 1 box marked:

50053 (110-N)
50054 (150-N)
50055 (185-N)
50056 (225-N)
50057 (300-N)
50058 (380-N)

N.B. For models from **500-N** to **840-N** (ref. fig. 28 and 29), the casing and insulation are contained in 3 boxes marked:

50087 (casing 500-N)
50088 (casing 500-N)
50089 (insulation 500-N)
50090 (casing 630-N)
50091 (casing 630-N)
50092 (insulation 630-N)
50093 (casing 730-N)
50094 (casing 730-N)
50095 (insulation 730-N)
50096 (front casing 840-N)
50097 (rear casing 840-N)
50098 (top casing 840-N)

N.B. For models from **1100-N** to **1600-N** (ref. fig. 30 and 31), the casing and insulation are contained in 4 boxes marked:

50074 (front casing 1100-N)
50075 (rear casing 1100-N)
50076 (top casing 1100-N)
50099 (rear panel 1100-N)
50074 (front casing 1320-N)
50077 (rear casing 1320-N)
50078 (top casing 1320-N)
50099 (rear panel 1320-N)
50079 (front casing 1600-N)
50080 (rear casing 1600-N)
50081 (top casing 1600-N)
50100 (rear panel kit 1600-N)

N.B. For the **1900-N** model (ref. fig. 32 and 33) the casing and insulation are contained in 5 boxes marked:

50079 (front casing 1900-N)
50082 (rear casing 1900-N)
50083 (top casing 1900-N)
50084 (central casing 1900-N)
50100 (rear panel kit 1900-N)

3.14 - ASSEMBLING CASING

65-N / 85-N

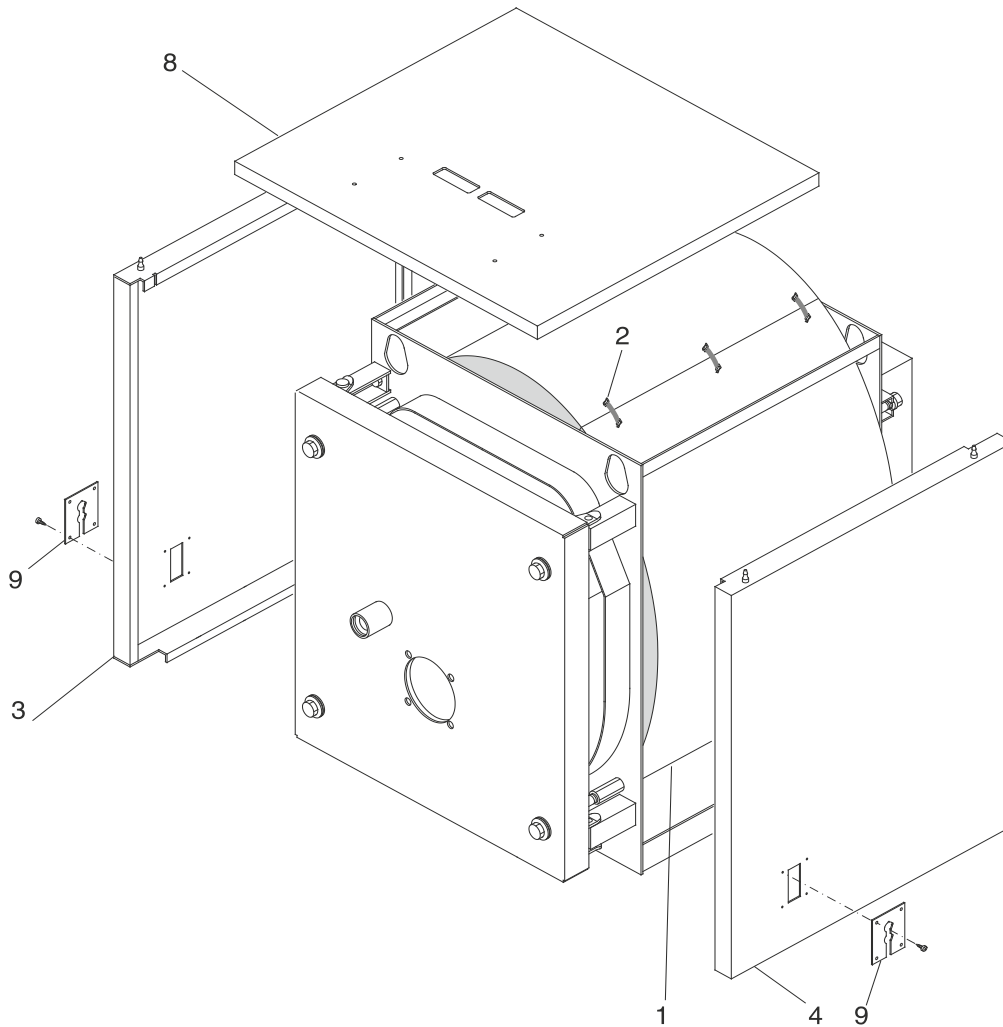
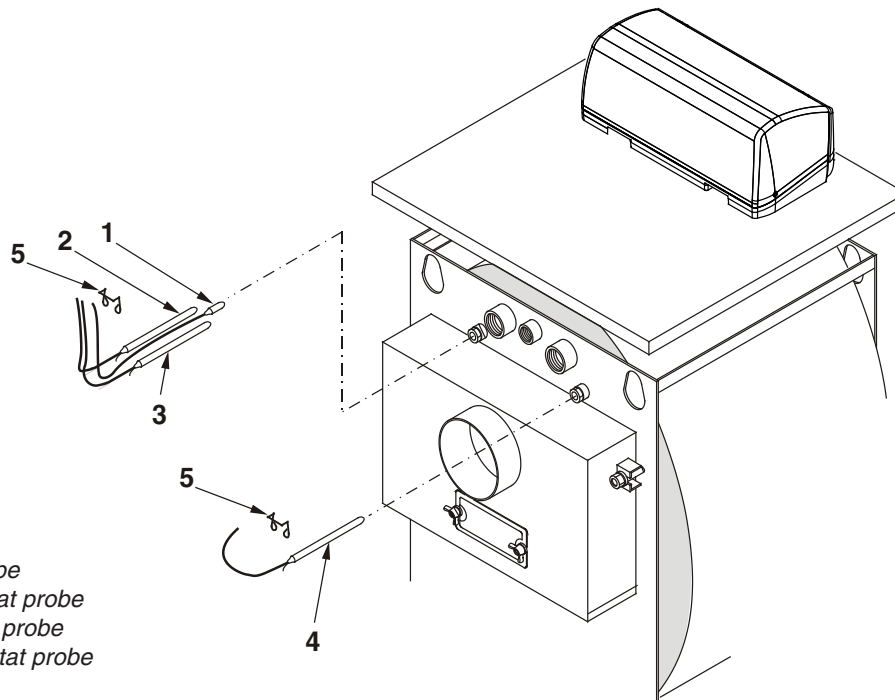

fig. 24

Assembly sequence (Ref. fig. 24, 25)

- A) Mount the insulation (pos. 1) of the boiler body and secure the 2 edges with the elastic straps (pos. 2) supplied in the accessory box, hooking them to the external fabric part of the insulation.
- B) Position the side panels (pos. 3 e 4) with the lower bend inside the L-shaped profile at the base of the boiler body and hook the upper part in the plate cuts.
To determine which is the right side and which is the left side, refer to the cable gland plates (pos. 9): they must face the front of the boiler.
- C) Fasten the 4 screws (pos. 5) to the sides on the front.
- D) Mount the junction panel of the 2 sides (pos. 7).
- E) Rotate the cover of the panel board frontwards after having removed the two screws on the side and insert the electric inlet cables and the outlet probe capillaries through the slots at the base.
Fit the panel board to the upper panel (pos. 8).
Fit the upper panel (pos. 8), complete with panel board, to the two sides of the casing.
- F) Insert the bulbs of the instruments in the conduits as indicated in in fig. 25 and wire the panel board to the power line, to the burner and to any pumps, etc.
Close the cover of the electric control board.
- G) Fix the rear panel (pos. 11) with the specific self-threading screws.
- H) Fix the boiler data plates to the side panel after having degreased the relevant part with the specific solvent.
The plates are included in the document envelope.

Installation instructions



- 1 Thermometer probe
- 2 Working thermostat probe
- 3 Safety thermostat probe
- 4 Minimum thermostat probe
- 5 Safety spring

fig. 25

Assembly sequence (Ref. fig. 26 and 27)

- A) Mount the insulation (pos. 1) of the boiler body and secure the 2 edges with the elastic straps (pos. 2) supplied in the accessory box, hooking them to the external fabric part of the insulation.
- B) Position the side panels (pos. 3 and 4) with the lower bend inside the L-shaped profile at the base of the boiler body and hook the upper part to plate junction profiles.
To determine which is the right side and which is the left side, refer to the cable gland plates on the front panels (pos. 11): they must face the front of the boiler.
- C) Fix the middle rear panel (pos. 15) and the top rear panel (pos. 8) with the specific self-threading screws.
- D) Rotate the cover of the panel board frontwards after having removed the two screws on the side and insert the electric inlet cables and the outlet probe capillaries through the slots at the base.
Fit the panel board to the upper panel (pos. 10).
Fit the upper panel (pos. 10), complete with panel board, to the two sides of the casing.
- F) Insert the bulbs of the instruments in the conduits as indicated in in fig. 27 and wire the panel board to the power line, to the burner and to any pumps, etc.
Close the cover of the electric control board.
Guide the burner plug through the side plate (pos. 11) on the preferred side and secure the cable with the cable gland supplied.
Fasten the plates (pos. 11) to the sides of the casing.
Secure the electric cables coming out from the rear of the boiler with the cable clamps, tightening them moderately.
- E) Fit the upper longitudinal panels (pos. 12 and 13) to the sides of the casing.
- F) Fix the boiler data plates (pos.14) to the side panel after having degreased the relevant part with the specific solvent.
The plates are included in the document envelope.

110-N÷380-N

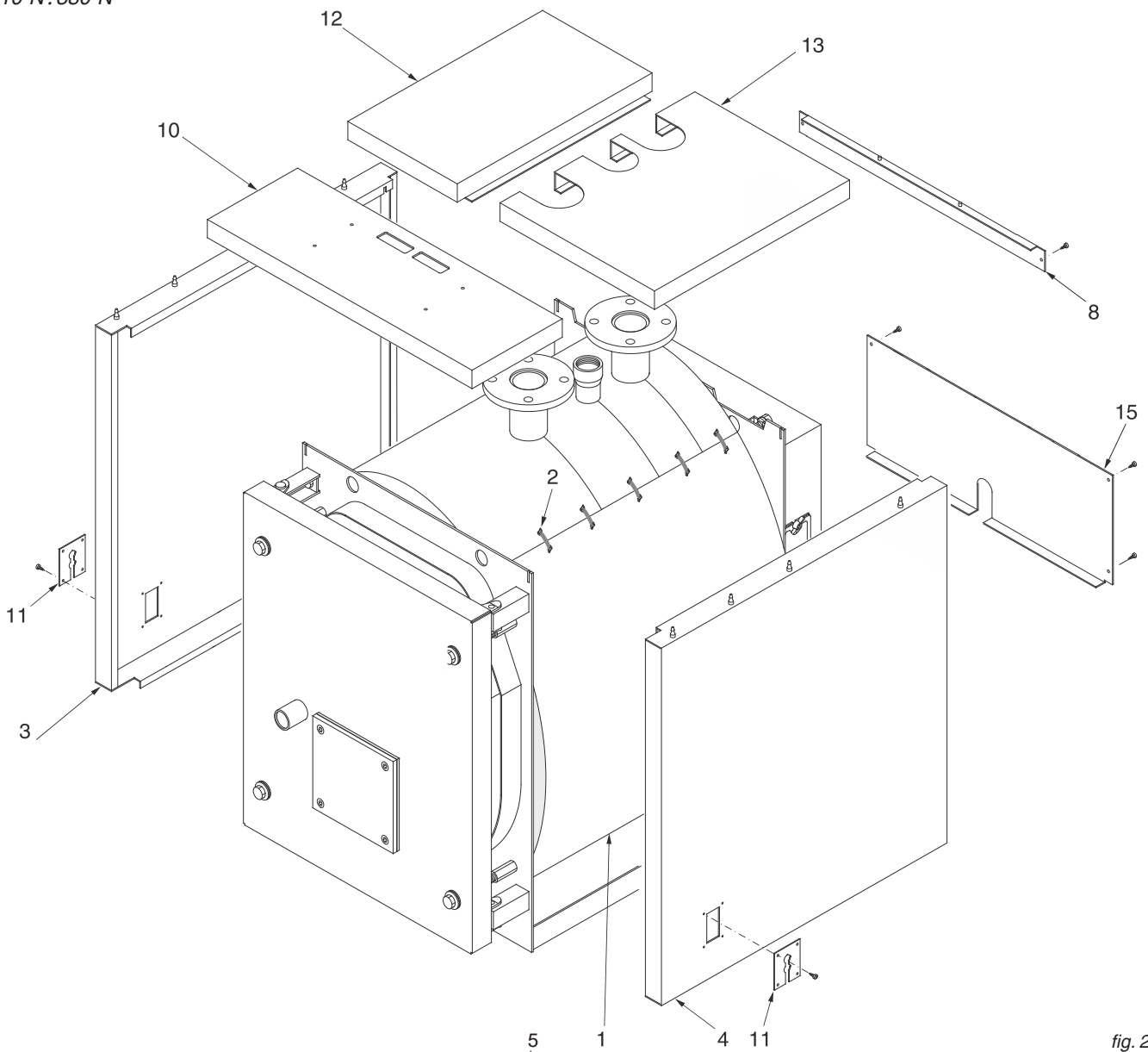

fig. 26

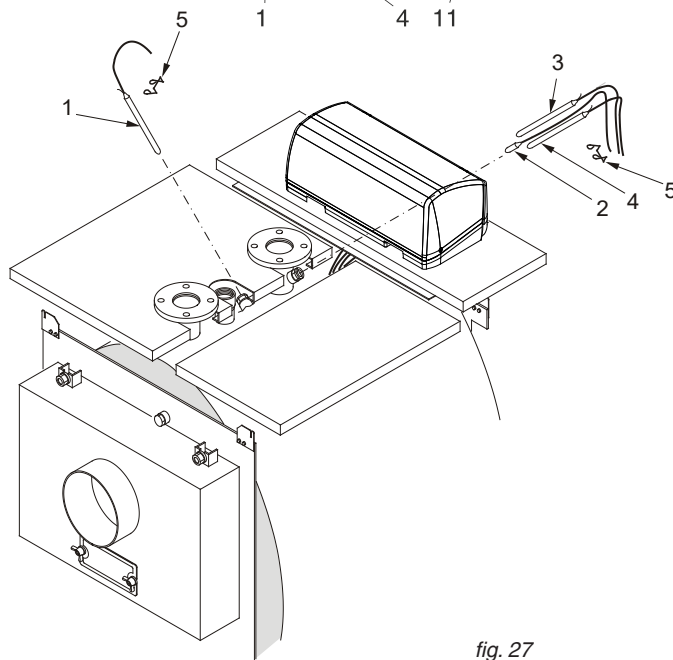

fig. 27

- 1 Safety thermostat probe
- 2 Thermometer probe
- 3 Working thermostat probe
- 4 Minimum thermostat probe
- 5 Safety spring

Installation instructions

Assembly sequence (Ref. fig. 28 and 29)

- A) Fasten the 4 top support brackets (pos. 1) of the side panels the boiler body with the relative screws and nuts (pos. 2, 3, and 4).
- B) Fasten the 4 middle (pos. 12) and 4 bottom support brackets (pos. 5) of the side panels the boiler body with the relative screws and nuts (pos. 2, 3, and 4).
- C) Position the insulation (pos. 6) of the boiler body and secure the 2 edges with the elastic straps (pos. 7) supplied in the accessory box, hooking them to the external fabric part of the insulation.
- D) Position the bottom side panels (pos. 9 and 18) hooking them to the support brackets pos. 5 & 12.
To determine which is the right side and which is the left side, refer to the hole in the cable gland plate: it must face the front of the boiler.
- E) Position the top side panels (pos. 8 and 17) hooking them to the support brackets pos. 1 and locking the pins on the bottom side.
- F) Fasten the 8 screws (pos. 10) to the top side panels on the front and rear internal side.
- G) Position at the back of the boiler body the bottom rear panel (pos. 26).
- H) Position the panel pos. 19 between the top side panels (pos. 8 and 17).
- I) Rotate the cover of the panel board frontwards after having removed the two screws on the side and insert the electric inlet cables and the outlet probe capillaries through the slots at the base.
Fit the panel board to the upper panel (pos. 13).
Fit the upper panel (pos. 13), complete with panel board, to the two sides of the casing.
The cables of the power line, pumps and mixer valve must go towards the rear of the boiler.
- L) Insert the bulbs of the instruments in the conduits as indicated in in fig. 29 and wire the panel board to the power line, to the burner and to any pumps, etc.
Close the cover of the electric control board.
Guide the burner plug through the side plate (pos. 14) on the preferred side and secure the cable with the cable gland supplied.
Fasten the plates (pos. 14) to the sides of the casing.
- M) Fit the upper longitudinal panels (pos. 21 and 25) hooking them to the sides.
- N) Fix the boiler data plates to the side panel after having degreased the relevant part with the specific solvent.
The plates are included in the document envelope.

500-N÷730-N

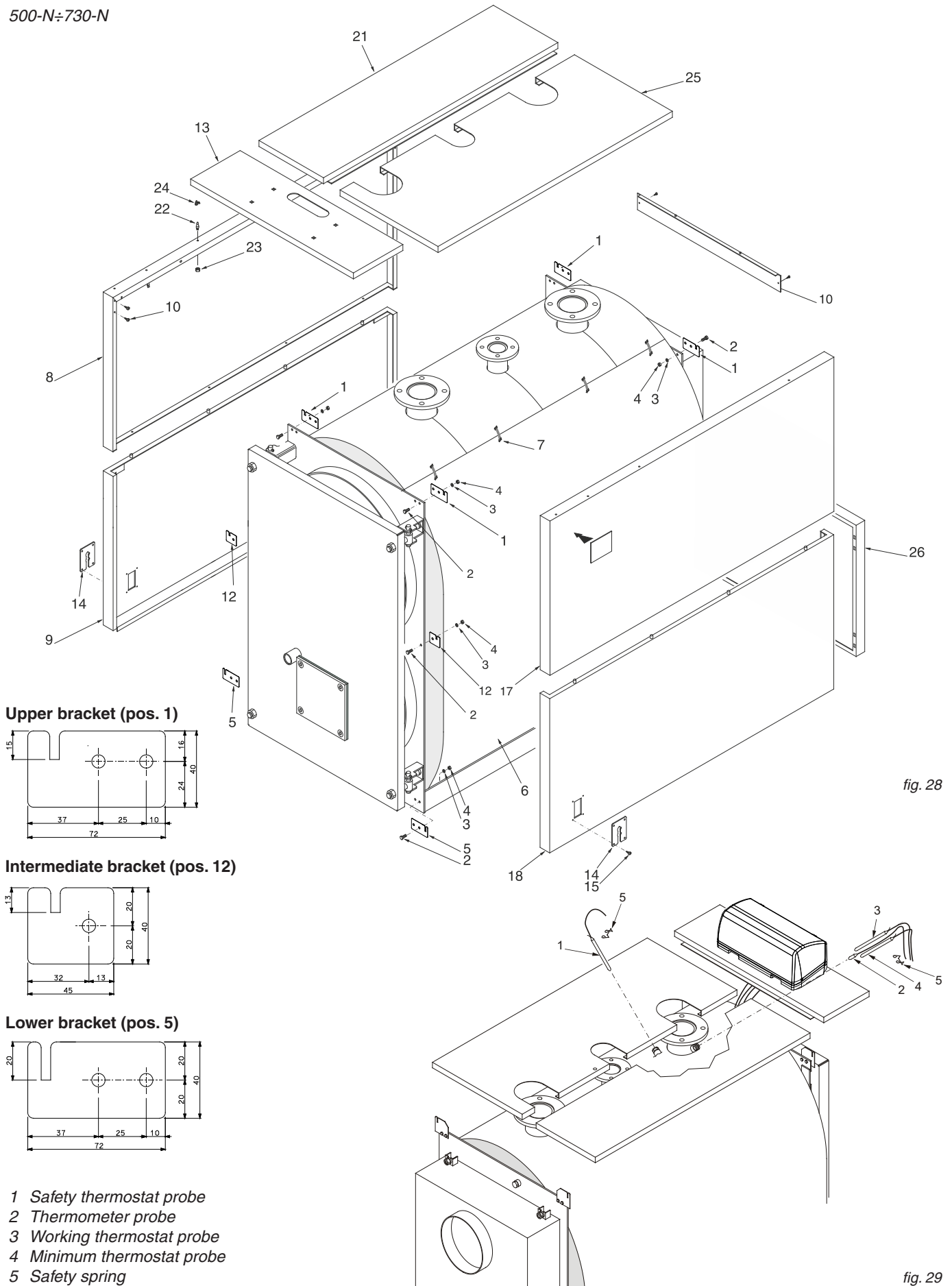

Installation instructions

Assembly sequence (Ref. fig. 30 and 31)

- A) Mount the insulation (pos. 1) of the boiler body and secure the 2 edges with the elastic straps (pos. 2) supplied in the accessory box, hooking them to the external fabric part of the insulation.
- B) Position the side panels (pos. 3, 4, 5, and 6) hooking them to the boiler body.
To determine which of the front sides is right and which is left, refer to the hole in the cable gland plate: it must face the front of the boiler.
- C) Fasten the 4 screws (pos. 7) to the sides pos. 4 and 6 on the top inner rear side.
- D) Rotate the cover of the panel board frontwards after having removed the two screws on the side and insert the electric inlet cables and the outlet probe capillaries through the slots at the base.
Fit the panel board to the upper panel (pos. 9).
Fit the upper panel (pos. 9), complete with panel board, to the two sides of the casing.
- E) Insert the bulbs of the instruments in the conduits as indicated in fig. 31 and wire the panel board to the power line, to the burner and to any pumps, etc.
- Close the cover of the electric control board.
Guide the burner plug through the side plate (pos. 16) on the preferred side and secure the cable with the cable gland supplied.
Fasten the plates (pos. 16) to the sides of the casing.
- F) Fix the top panels pos. 9, 10 and 11 to the casing sides.
- G) Fit the junction panel (pos. 14) of 2 sides.
- H) Fix the boiler data plates to the side panel after having degreased the relevant part with the specific solvent.
The plates are included in the document envelope.

840-N

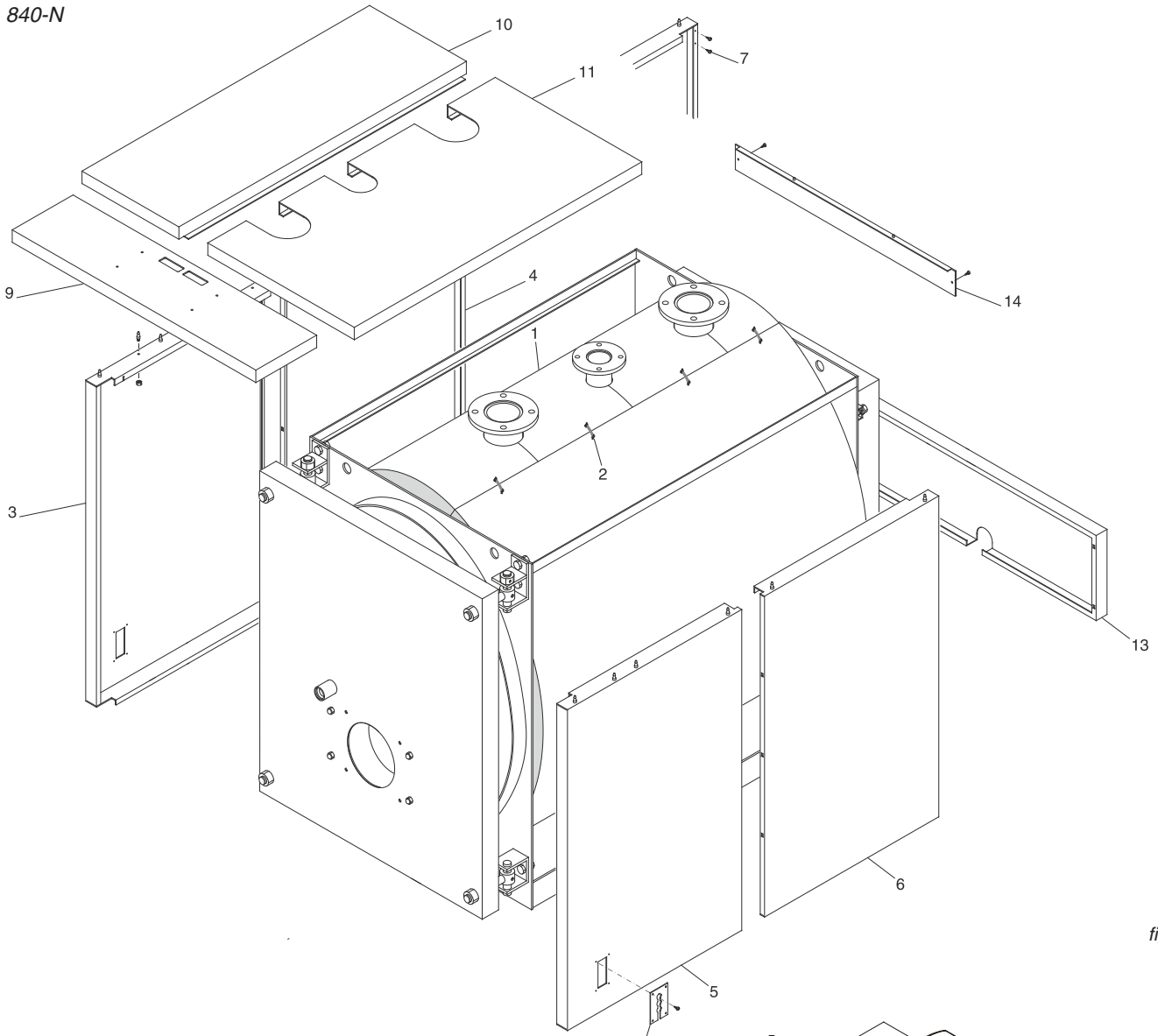
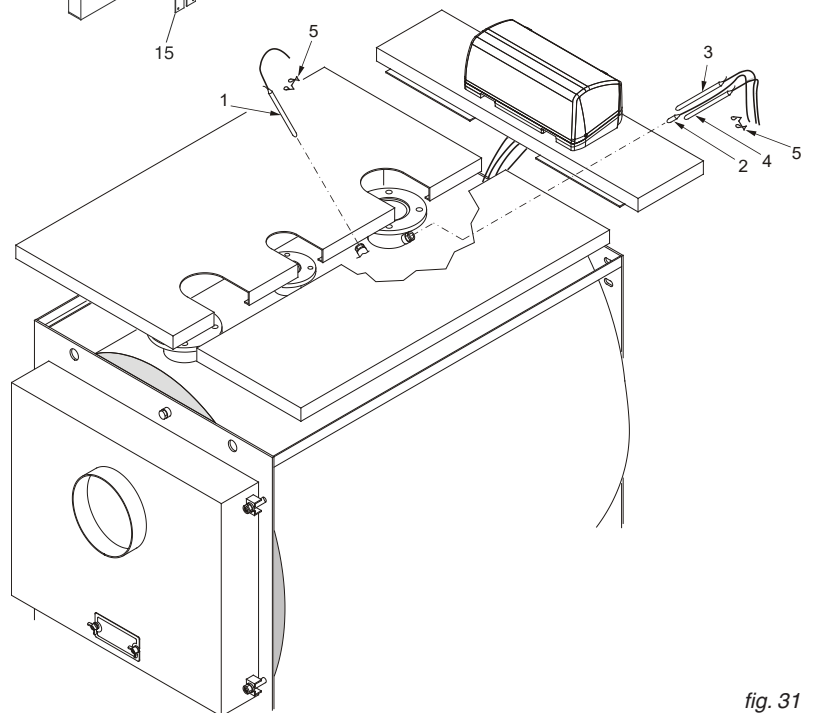

fig. 30



- 1 Safety thermostat probe
- 2 Thermometer probe
- 3 Working thermostat probe
- 4 Minimum thermostat probe
- 5 Safety spring

fig. 31

Installation instructions

Assembly sequence (Ref. fig. 32 and 33)

- A) Mount the insulation (pos. 1) of the boiler body and secure the 2 edges with the elastic straps (pos. 2) supplied in the accessory box, hooking them to the external fabric part of the insulation.
Perform a sufficient cut on the top part near the bulb holders.
- B) Position the side panels (pos. 3a, 3b and 4a, 4b) with the lower bend inside the L-shaped profile at the base of the boiler body and hook the upper part to plate junction profiles.
To determine which is the right side and which is the left side, refer to the cable gland plates on the front panels (pos. 5): they must face the front of the boiler.
- C) Mount the bottom rear panel (pos. 8).
- D) Fit the upper rear panel (pos. 9).
- E) Rotate the cover of the panel board frontwards after having removed the two screws on the side and insert the electric inlet cables and the outlet probe capillaries through the slots at the base.
- Fit the panel board to the upper panel (pos. 11).
Fit the upper panel (pos. 11), complete with panel board, to the two sides of the casing.
- F) Insert the bulbs of the instruments into the conduits as indicated in fig. 33 and wire the panel board to the power line, to the burner and to any pumps, etc.
Close the cover of the electric control board.
Guide the burner plug through the side plate (pos. 5) on the preferred side and secure the cable with the cable gland supplied.
Fasten the plates (pos. 5) to the sides of the casing.
Secure the electric cables coming out from the rear of the boiler with the cable clamps, tightening them moderately.
- G) Fit the upper longitudinal panels (pos. 12 and 13) to the sides of the casing.

1100-N÷1900-N

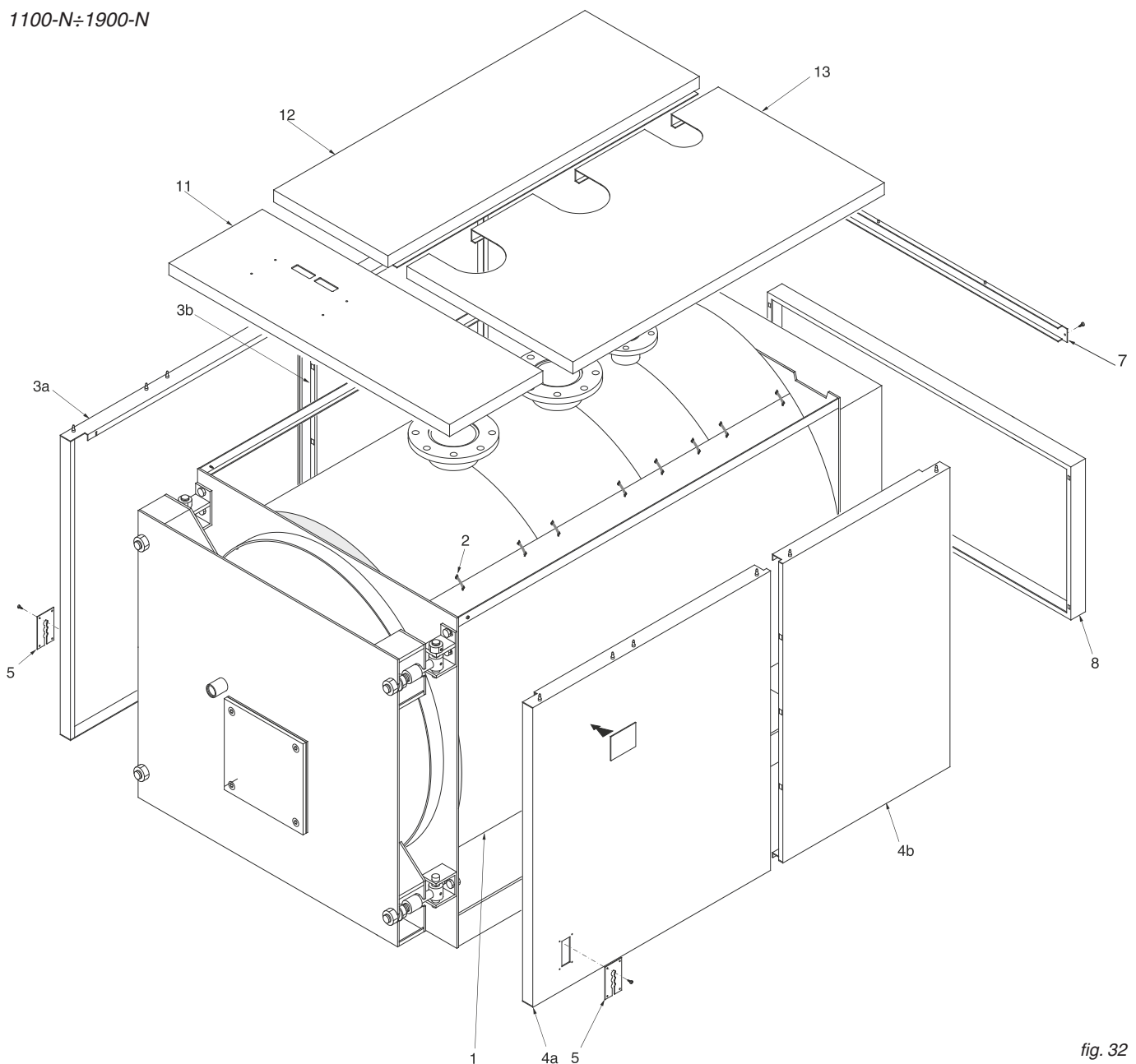

fig. 32

H) Fix the boiler data plate (pos. 14) to the side panel after having degreased the relevant part with the specific solvent.

The plates are included in the document envelope.

Probe insertion sequence

Following this sequence, insert the probes of the instruments in the bulb holder/s on the top of the boiler (Ref. fig. 33): of the thermometer (pos. 1), of the working thermostat (pos. 2), of the safety thermostat (pos. 3), of the minimum thermostat (pos. 4). It is recommended to insert the probes all the way in the relative bulb holders for best contact. Then insert the contact spring and fasten the capillaries with the fixing clip/s (pos. 5).

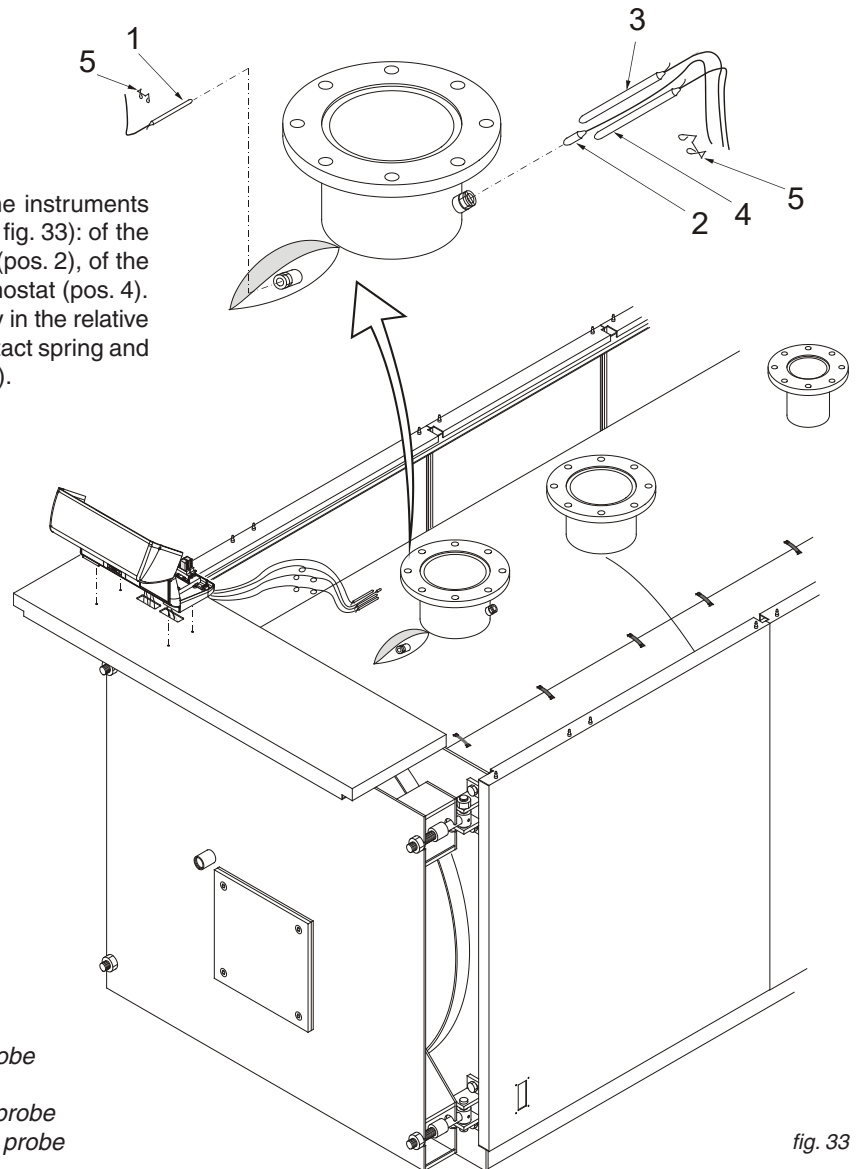

fig. 33

3.15 - ELECTRICAL CONNECTIONS

General warnings

The electrical safety of the appliance is guaranteed only when it has been properly connected to an efficient earthing system carried out as intended by safety standards in force: pipes of the gas, water and heating systems are absolutely unsuitable as earthing electrodes.

It is necessary to verify this fundamental safety requirement. If in doubt, have the electric system carefully checked by professionally qualified personnel as the manufacturer is not liable for damage caused by failure to provide an earthing system.

Have professionally qualified personnel check that the electric system is adequate for the maximum power absorbed by the appliance, indicated on the data plate. Make sure in particular that the cross-section of the cables is suitable for the power absorbed by the appliance.

Adapters, multiple sockets and/or extension cords cannot be used to power the appliance.

Use of any type of component using electric energy requires the observance of some fundamental rules, such as:

- Do not touch the appliance with wet and/or moist parts of the body and/or in bare feet.
- Do not pull the electric cables.
- Do not leave the appliance exposed to atmospheric agents (rain, sun, etc.) unless expressly designed.
- Do not allow children or unskilled persons to use the appliance.

230V electric power supply connection

The electrical connections are illustrated in chap. 3.16, 3.17, 3.18, 3.19, 3.21.

Boiler installation requires connection to a 230 V - 50 Hz electric mains: this connection must be performed up to standard as intended by current IEC regulations.



Danger!

Only a qualified technician may perform the electrical installation.

Before performing connections or any type of operation on electrical parts, always disconnect electrical power and make sure that it cannot be reconnected accidentally.

Remember that a bipolar switch must be installed on the boiler power line with over 3 mm between contacts, easy to access, making maintenance quick and safe.



The power cable must be replaced by authorised technical personnel. Failure to comply with the above can jeopardise the safety of the appliance.

4 STANDARD PANEL BOARD

4.1 - PANEL BOARD FUNCTIONS DESCRIPTION

Through the main switch [11] the panel board and all the equipments connected to it will be under power.

The switches [12] & [13] switch On and OFF the power to the burner and the Heating pump (via a relay, if necessary). With the thermostat [32] the working temperature of the boiler can be adjusted. This thermostat is provided with a DPDT contact, for the control of a two stage burner.

The differential between the switching points of the two double pole is 6°C (not adjustable).

The minimum thermostat, accessible through the opening of the panel board cover, switches OFF the C.H. pump during the reacing of the steady state and up to the obtention of 50 °C within the boiler. On the electrical supply line to the boiler a switch with fuses is to be forseen.

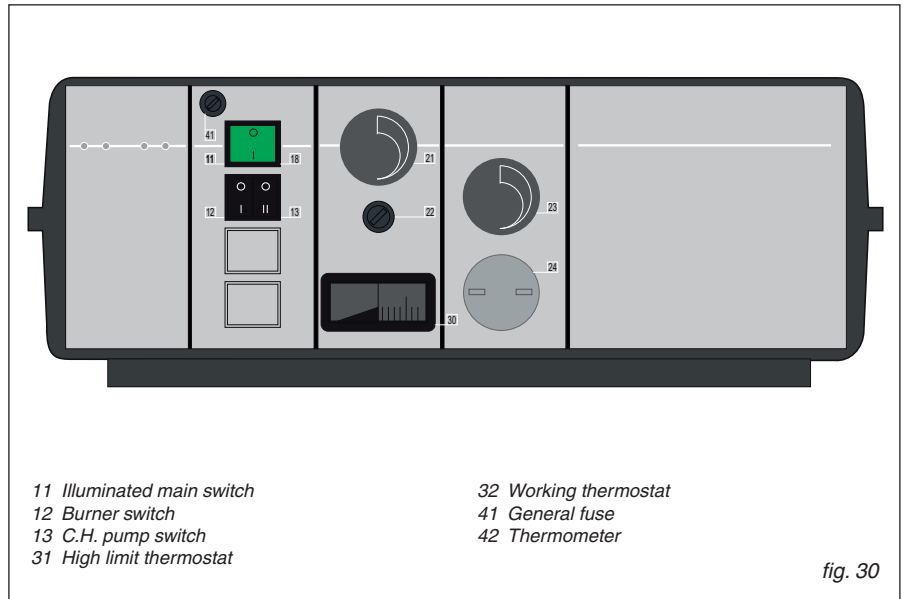

Installation instructions

4.2 ELECTRICAL WIRING DIAGRAM OF A GENERIC BURNER TO THE BASIC CONTROL PANEL

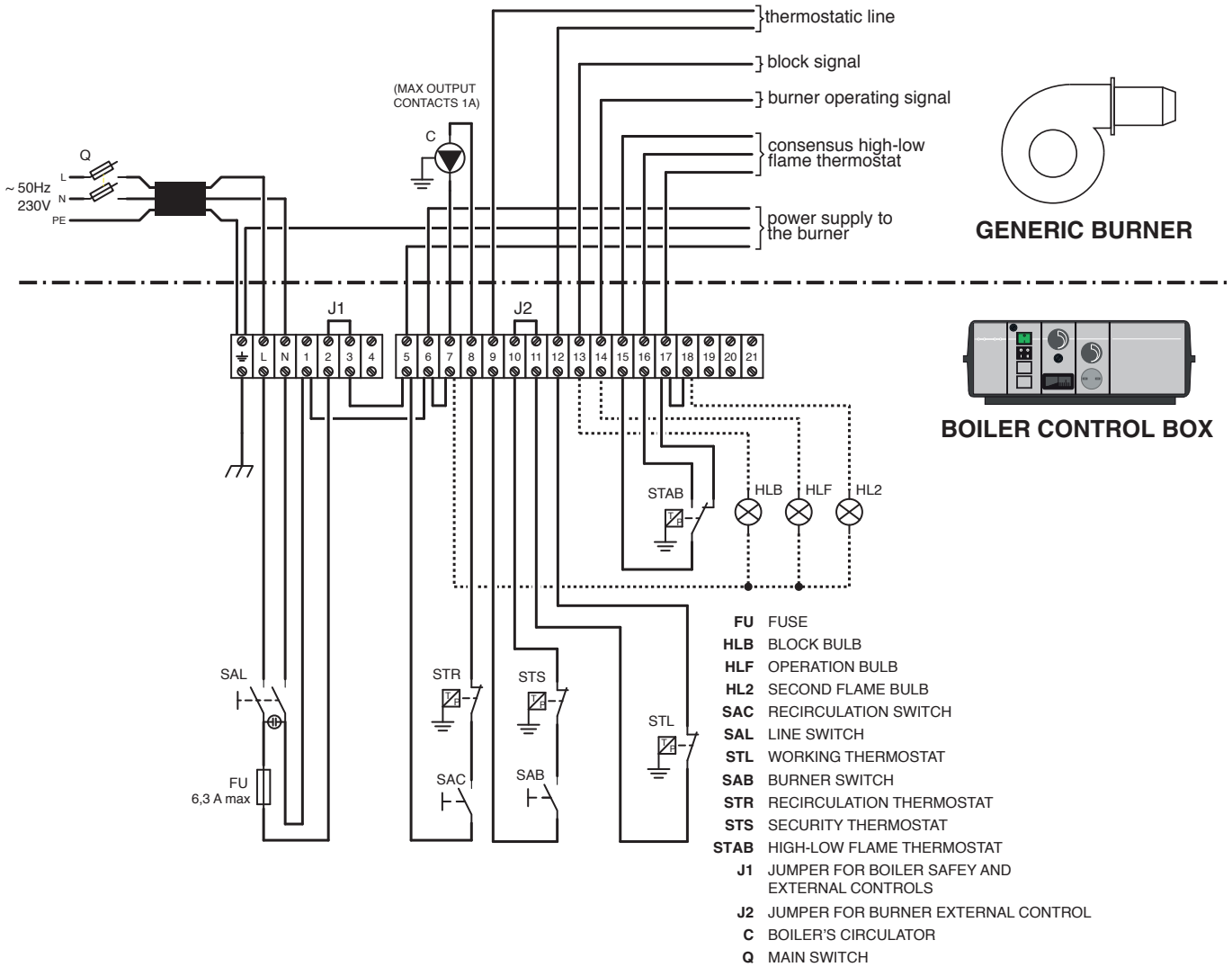

4.3 ELECTRICAL WIRING DIAGRAM OF AN ELCO SINGLE PHASE BURNER TO THE BASIC CONTROL PANEL

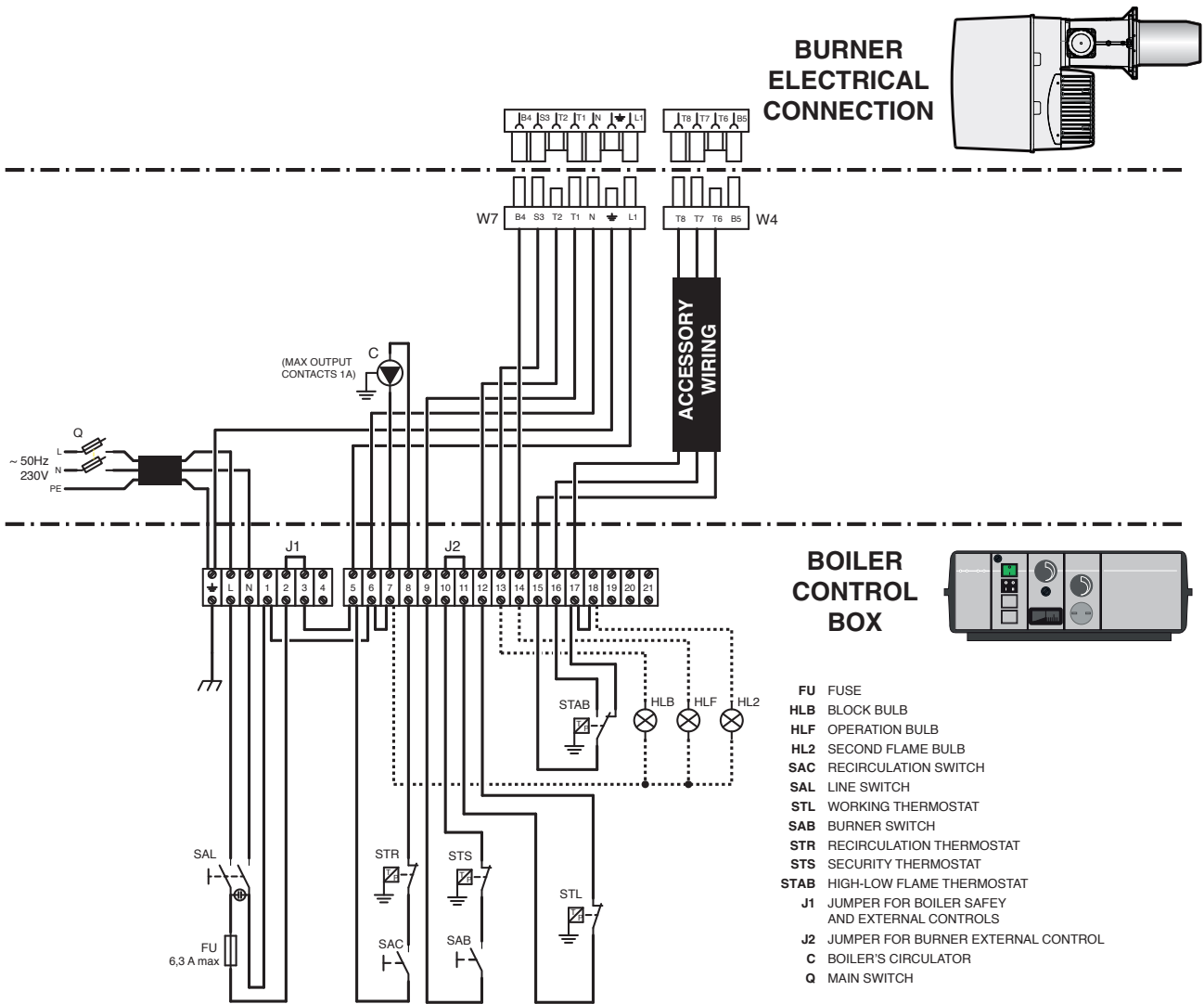

Installation instructions

4.4 ELECTRICAL WIRING DIAGRAM OF AN ELCO THREE PHASE BURNER TO THE BASIC CONTROL PANEL

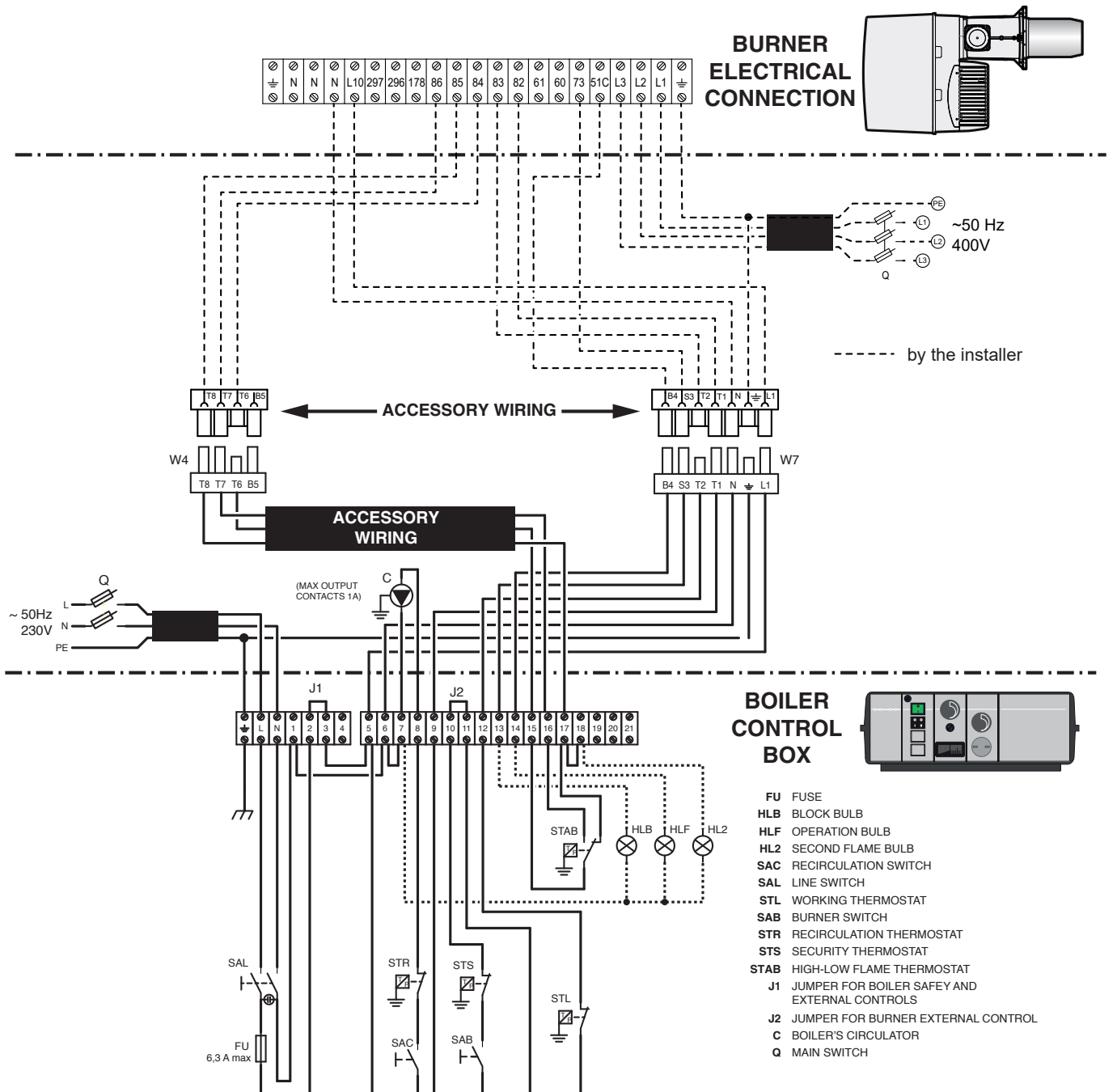

4.5 ELECTRICAL WIRING DIAGRAM OF AN ECOFLAM SINGLE PHASE BURNER TO THE BASIC CONTROL PANEL

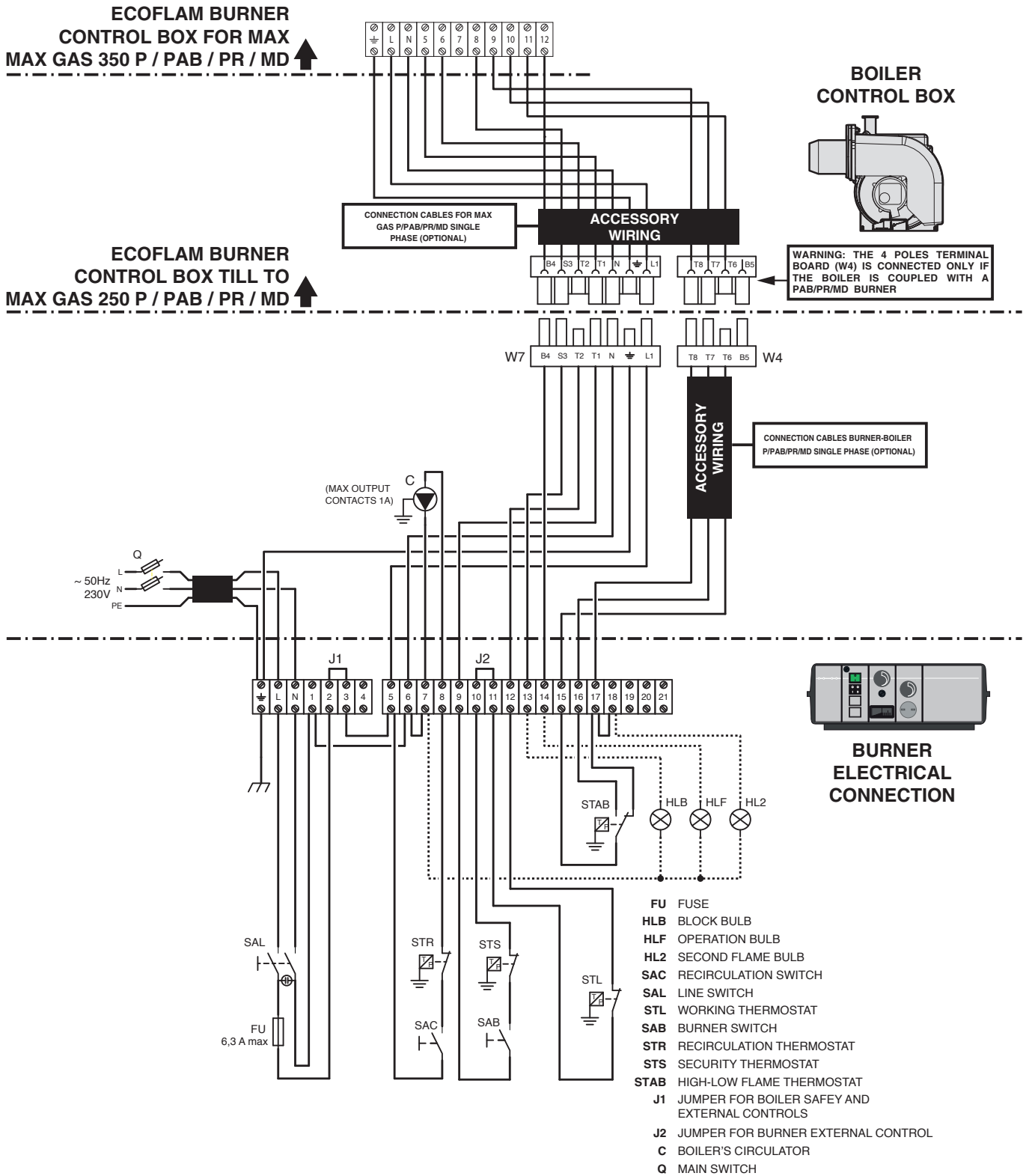

Installation instructions

4.6 ELECTRICAL WIRING DIAGRAM OF AN ELCO THREE PHASE BURNER TO THE BASIC CONTROL PANEL

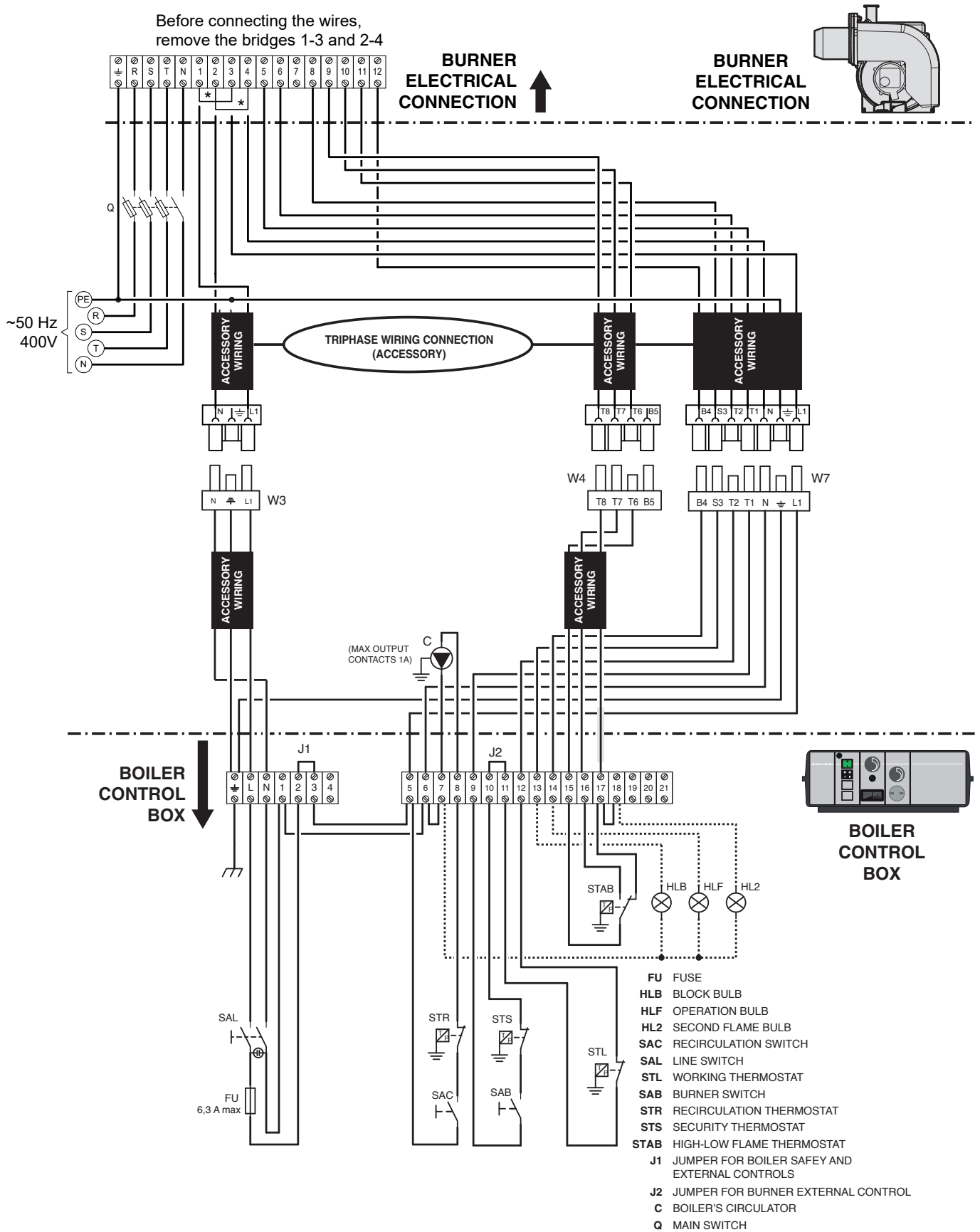

4.09 - COMMISSIONING

Preliminary checks



Commissioning must be done by professionally qualified personnel. Ecoflam will not be held liable for damage to persons, animals or objects due to failure to comply with the above instruction.

Before commissioning the boiler, check that:

- installation complies with standards UNI 7129 and 7131 for the gas part and with standards IEC 64-8 and 64-9 for the electrical power;
- the adduction of combustion air and flue gas evacuation are performed correctly according to that laid down by standards in force (UNI 7129/7131);
- the fuel feed system is dimensioned according to the flow rate required for the boiler and is provided with all safety and control systems prescribed by current standards;
- the power supply of the boiler is 230V - 50Hz;
- the system is filled with water (approximately 1 bar pressure on the pressure gauge with the pump stopped);
- any system shut-off gate valves are open;
- the gas feed valves are open;
- there is no gas leakage;
- the external main switch is connected;
- the system safety valves are not blocked and are connected to the sewer system drainage;
- there is no water leakage;
- ventilation conditions and minimum distances are guaranteed to perform maintenance.

Switching boiler on and off

To switch the boiler on and off, see the “SYSTEM MANAGER OPERATING INSTRUCTIONS” booklet.

Information for system manager

The system manager must be instructed concerning the use and operation of his heating system, in particular:

- Give the system manager the “SYSTEM MANAGER OPERATING INSTRUCTIONS”, as well as the other appliance documents inserted in the envelope inside the packaging. **The system manager must keep this documentation for future consultation.**
- Inform the system manager about the importance of the air vents and the flue gas exhaust system, highlighting their essential features and the absolute prohibition of modifying them.
- Inform the system manager concerning control of the system's water pressure as well as operations to restore it.
- Inform the system manager concerning correct control of temperatures, control units/thermostats and radiators to save energy.
- Remember that the system must receive regular maintenance at least once a year and a combustion analysis must be performed in the timetable foreseen by standards in force.
- Should the appliance be sold or transferred to a new owner or if you move and leave the appliance, always make sure that the instruction booklet accompanies it in order to be consulted by the new owner and/or installer.

ECOMAX 3SC boilers are forced circulation boilers: it is therefore necessary to make sure that water circulates while the boiler is running.

Do not allow the burner to run without the system pump being activated; otherwise the safety thermostat could be triggered.

The return temperature must not drop below 50°C to avoid, or at least limit, flue gas condensation which causes premature deterioration of the boiler.

The working temperature of the boiler can therefore be adjusted between 60 and 80°C. Room temperature will be regulated by the mixer valve commanded by the heating controller.

The system must slowly reach the operating temperature, with the eventual insertion in the secondary ring circuit, to avoid the temperature from dropping below 50°C.

It is always recommended to install an anti-condensation or recirculation pump (between the flow and return lines of the boiler).

Returns to low temperatures, below 50°C, cause the flue gas to condense corroding the heat exchange surfaces. You must therefore pay the utmost attention while operating the system.

Corrosion caused by acid condensation of combustion products is not covered by the warranty as it is attributable to operation of the system alone.

4.10 - ADJUSTING THE BURNER



The following instructions are intended exclusively for **service personnel authorised by the manufacturer of the burner**.

Burner calibration and preliminary operations are described in the burner's instruction booklet.

Gas-fired burners are equipped with a gas valve with which the flow rate can be determined: upon commissioning the actual thermal flow rate **must always** be controlled by means of the counter on the main piping, making sure it is not below the minimum value on the data plate of the boiler.

When the burner is adjusted properly, the following values should be obtained, measured at the chimney by a specific analyser.

With natural gas:

- CO₂ = 9÷10%

- Flue gas temperature \cong 125÷140°C

(values for boiler cleaned with water at ~ 70°C).

The flow rate of the fuel should be adjusted to the actual requirement of the system.

4.11 - REMOVING FLUE GAS TURBULATORS

ECOMAX 3SC boilers have been designed to be used at the declared nominal output.

ECOMAX 3SC boilers are equipped with flue gas turbulators inside each smoke duct (see page 8).

The correct position of the turbulators inside the smoke pipes determines the heat output of the boiler and therefore the flue gas temperature at the chimney.

Upon commissioning, after at least 30 minutes, it is advisable to check the flue gas temperature at the chimney.

Aside from the cleaning tools, each ECOMAX 3SC boiler is equipped with a special extractor which allows to pull the turbulators from the smoke pipes.

In the reinsertion phase of the turbulators, comply with the position measurements indicated on page 8.

Extraction of turbulators

Detail 1:

Mount the brush rod on the turbulator extractor.

Pull the pin from the extractor.

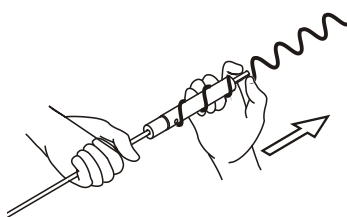

Detail 2:

Put the pin in the cross hole using a hammer.

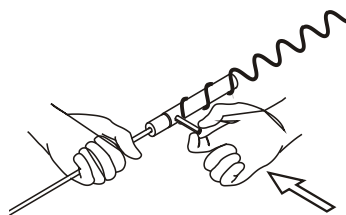

Detail 3:

Screw the extractor onto the turbulator.

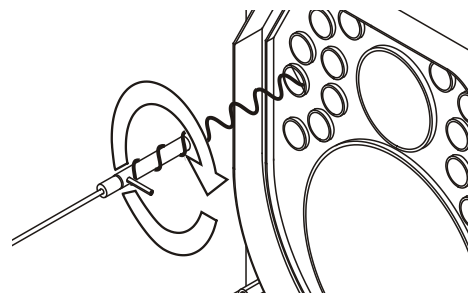

Detail 4:

Turn until the turbulator is released.

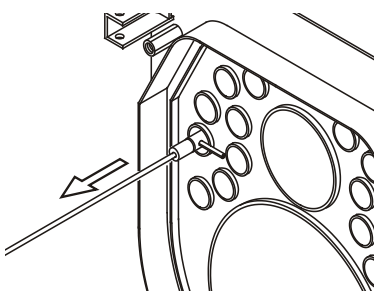

Detail 5:

Remove the turbulator.

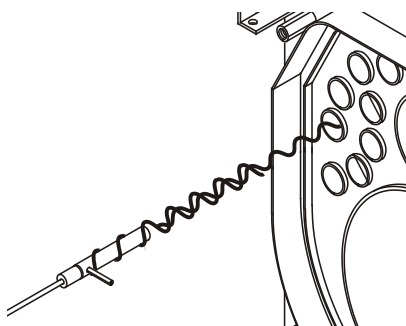

Detail 6:

Turn the extractor anticlockwise and release the turbulator.

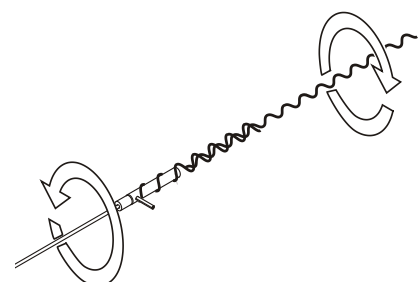

The procedure from detail 3 to 6 must be repeated for all turbulators.

fig. 41

5

INSPECTIONS AND MAINTENANCE



Inspections and maintenance performed professionally and according to a regular schedule as well as the use of original spare parts are of the utmost importance for fault-free operation of the boiler and to guarantee its long life. Yearly maintenance of the appliance is mandatory in compliance with Laws in force.



Failure to perform Inspections and Maintenance can entail material and personal damage.

We therefore recommend stipulating an inspection or maintenance contract.

Inspections help to determine the actual status of the appliance and to compare it with the nominal status. This is done through measuring, controls and observation.

Maintenance is required to eliminate any differences between the actual status and the nominal status. This is normally done by cleaning, setting and replacing individual components subject to wear.

Maintenance intervals and their extent are determined by a specialist based on the status of the appliance ascertained through inspection.

Inspection and maintenance jobs must be performed in the order shown on page 47.

Inspection and maintenance instructions



To assure long-term functioning of your appliance and to avoid altering its approved status, only original Ecoflam spare parts must be used.

Before proceeding with maintenance, always perform the following operations:

- Disconnect the electric mains switch.
- Isolate the appliance from the electric mains by means of an isolated device with a contact opening of at least 3 mm (e.g. safety devices or power switches) and make sure that it cannot be re-connected accidentally.
- Close the gas shut-off valve upstream the boiler.
- Close any shut-off valves on the heating flow and return pipes.

After having completed all maintenance work, always perform the following operations:

- Open the heating flow and return pipes.
- If necessary, restore the heating system pressure until it reaches the static pressure relative to the highest point of the system.
- Open the gas shut-off valve.
- Reconnect the appliance to the electric mains and engage the switch.
- Make sure the appliance is gas tight and watertight.
- Vent the heating system and restore pressure if necessary.

Should you decide to temporarily deactivate the boiler, you must:

- a) shut off the various supplies: electric, water and fuel;
- b) empty the water system if antifreeze is not used.

Boiler body maintenance



Danger!
Before performing any maintenance, make sure the boiler and its components have cooled down.

Disconnect the boiler from the electric mains and shut the gas supply to the appliance.



Attention!
Before cleaning the boiler body, protect the panel board against any water sprays.

Once a year, at the end of the heating season, the boiler must receive a general cleaning.

Before performing any maintenance, make sure that all the precautions referred to in the previous point have been taken.

To proceed with maintenance you must:

- disconnect power by acting on the main switch;
- remove the burner, which could be overhauled at the same time;
- open the furnace door to access the combustion chamber;
- remove the smoke chamber access door;
- pull the smoke turbulators off;
- brush the smoke ducts energetically to remove any trace of filth.

Checking status of gaskets and insulation fibres



The insulation fibre of the door can show cracks after a short time of operation; this however does not reduce its insulation capacity nor jeopardise its lifespan. Check the status of the seal gasket which must not show signs of deterioration; if so, it must be replaced, using only original spare parts.

Check the status of the smoke chamber inspection cover gasket.
Replace it if worn, using only original spare parts.

Maintenance of burner

Burner maintenance must be carried out by personnel authorised by its manufacturer (or else the warranty shall be terminated).

Checking ignition electrode

Burner maintenance must be carried out by personnel authorised by its manufacturer (or else the warranty shall be terminated).

Components to check during yearly inspection

COMPONENT:	VERIFY:	CONTROL/INTERVENTION MEASURE:
Ts (safety thermostat)	Does the thermostat place the boiler in safety when overheating?	Bring the boiler to operating temperature with the pumps stopped.
System expansion vessel	Does the vessel contain the right amount of air?	Check the nitrogen pressure. Pressurise the boiler (open the pump bleeder). Open the heating circuit closing valves.
Door gaskets	Does smoke seep through the door gaskets?	Further tighten the door screws. Replace the sealing gasket and possibly the internal gasket of the door.
Smoke chamber gaskets	Does smoke seep through the smoke chamber gaskets?	Further tighten the smoke chamber nuts. Replace the sealing gaskets.
Smoke turbulators	Are the smoke turbulators in place and the smoke ducts clean?	Perform a general cleaning with the supplied brush.

Ecoflam

Ecoflam Bruciatori S.p.A.

Via Roma, 64 - 31023 Resana (TV) - Italy

Tel. +39 0423 719500

Fax +39 0423 719580

<http://www.ecoflam-burners.com>

e-mail: export@ecoflam-burners.com

Società soggetta alla direzione e al coordinamento di Ariston Thermo S.p.A.

Via A. Merloni, 45 - 60044 Fabriano (AN) - CF 01026940427

Ecoflam Bruciatori S.p.A. reserves the right to make any adjustments, without prior notice, which is considered necessary or useful to its products, without affecting their main features

Ecoflam Bruciatori S.p.A. si riserva il diritto di apportare ai prodotti le modifiche che riterrà necessarie o utili, senza pregiudicarne le caratteristiche principali.

La maison Ecoflam Bruciatori S.p.A. se réserve le droit d'apporter les modifications qu'elle jugera nécessaires ou utiles à ses produits sans pour autant nuire à leurs caractéristiques principales

Ecoflam Bruciatori S.p.A. se reserva el derecho a introducir en sus productos todas las modificaciones que considere necesarias o utiles, sin perjudicar sus características

"Ecoflam Bruciatori S.p.A." оставляет за собой право вносить в конструкцию оборудования любые необходимые изменения без особого предупреждения.

Ecoflam Bruciatori S.p.A. *behält sich das Recht vor, ohne Beeinträchtigung der wesentlichen Eigenschaften für notwendig oder sinnvoll erachtete Änderungen an den Produkten vorzunehmen.*